

# Sleeve and Flanged Bearings



LLOYD'S REGISTER  
TYPE APPROVED PRODUCT

PRODUCT INFORMATION AND SELECTION GUIDE

Duramax Marine® is an ISO 9001:2015 Certified Company

# DURAMAX MARINE®





# Johnson® CUTLESS® BEARINGS

## The Water-Lubricated Bearing That Has Nothing More To Prove.

It's proven itself for years at sea. No other water-lubricated bearing is used in more vessels worldwide than a Johnson Cutless® Rubber Bearing. It has set industry standards for decades in the harshest working environments, earning the trust of more marine professionals than any other bearing. The performance and operating characteristics of our resilient bearings are unique when compared to other water-lubricated bearings. 90% of the U.S. Navy surface ships and submarines run with the same water-lubricated bearing technology.

## Johnson Cutless® is Designed for Unmatched Performance and Long Life.



### High Quality Materials & Design.

Johnson Cutless® Sleeve and Flanged Bearings for heavy-duty commercial, government and pleasure craft applications, feature a specially formulated nitrile molded rubber lining firmly bonded to a shell material. Shells for sleeve bearings are seamless naval brass and are also available with a rugged non-metallic shell. Shells for flanged bearings are one-piece centrifugally cast naval bronze with an integral flange.

Other types of shells, such as stainless steel, Monel, or aluminum can be furnished to order. All bearings are precision machined to close tolerances and fully inspected.

The rubber, a proprietary formulation of extremely tough chemical and oil-resistant nitrile, is molded to fit the shaft in accordance with U.S. Navy BuShips approved clearances for efficient water lubrication.

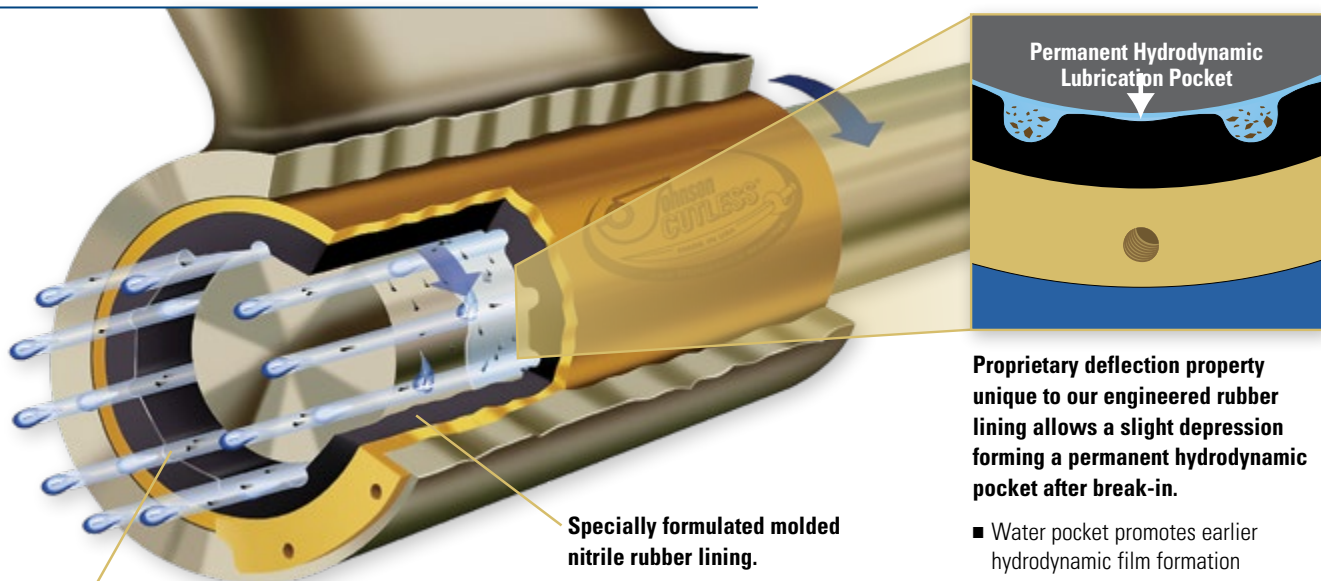

### Engineered geometry optimized for superior performance.

- Prevents shaft whip and absorbs vibration
- Assures maximum water lubrication
- Flushes abrasives away, preventing scoring of shaft

### Specially formulated molded nitrile rubber lining.

- Permanently bonded to a precision-machined naval brass outer shell
- Resists oil, grease and chemicals

### Proprietary deflection property unique to our engineered rubber lining allows a slight depression forming a permanent hydrodynamic pocket after break-in.

- Water pocket promotes earlier hydrodynamic film formation
- Pocket significantly reduces friction and wear
- The longer a Cutless® runs the better it gets

## Water -The Ideal lubricant.

Water is the ideal lubricant because of its non-compressibility, cooling properties and abundant availability. When contained between sliding surfaces it forms a lubricating film with low coefficient of friction. And water is, of course, non-polluting. In rubber-lined bearings for metal shafts, water as a lubricant is at its most efficient -owing to its affinity for metal, but not for rubber. With Johnson Cutless® rubber bearings, the water enters the grooves and moves radially between the propeller shaft and the rubber. Contaminants and abrasives are flushed away through the grooves.

## Better Concentricity.

Some bearings are manufactured using centerless grinding techniques to finish the outside diameter. Centerless grinding the shell on a sleeve bearing provides a fine finish, but it may not be an indication of a high quality bearing. Since the centerless grinding process does not take the inside diameter of the bearing into account, the centers of the outside diameter and inside diameter may not be the same. When you install a bearing like this into a housing, the shaft may be off-center in the bearing. Johnson Cutless® Bearings are machined on the inside diameter. Once the inside diameter is bored to the correct dimension, a mandrel is inserted and the outside diameter is turned to the correct dimension. This results in good bearing concentricity and provides you with a quality product you can trust.



## Class II Bearing on US Navy Qualified Products List.

Duramax® Marine LLC has gone to great lengths to provide you with one of the best quality and highest-performing bearings available. Johnson Cutless® Bearings meet all requirements of MIL-DTL-17901C (SH) Class II. This United States military specification is more than just a classification approval; it is a stringent set of performance tests that a bearing must pass to become approved.

## Quality Inspection.

After machining the bearings, Duramax® Marine LLC inspects them to verify the accuracy of dimensions. Plug gages, one of the most accurate ways to measure a rubber bearing, are used on bearings for shaft sizes under 6-inches (152.40mm) in diameter. For larger sizes, Duramax® Marine LLC inspectors use ID micrometers. The bearings are also inspected for blemishes, imperfections and delamination in both the rubber and shell material. The bond between the rubber and shell material is also checked.

## Research & Development Program.

When a company is dedicated to producing the highest quality bearings, research and development becomes a critical aspect of creating technology for the industry. Duramax® Marine LLC has over 50 years of experience in the bearing business and operates a bearing test laboratory for the development of new bearing materials and performance testing of competitive materials. As a result, Duramax® Marine LLC is looked to as a leader in water-lubricated bearing technology and will continue to innovate and to provide you with longer lasting, better-performing bearings.

## Excellent Distribution & Availability.

In addition to high quality bearings, Duramax® Marine LLC is committed to having the bearings available for you when you need them. This is accomplished with field warehouses around the world. Duramax® Marine LLC has one of the largest distribution networks in the industry. The answer to your bearing needs is only a telephone call, fax or email away. If the bearing is not available locally, chances are it can be shipped from another location from stock.



# Naval Brass Sleeve Bearings

## INCH SIZE SERIES



Johnson Cutless® Naval Brass Sleeve Bearings adapt equally well to strut and stern tube mounts, and are often used effectively as rudder-stock and pintle bushings. Bearing diameters are precision fitted to the designated shaft size with the correct clearance for efficient water lubrication. External brass shells are machined and polished to provide easy fitting. Specially formulated oil and chemical resistant nitrile rubber is securely bonded to the shell. Units with thin shells are available for the struts of small craft. Sleeve bearings are usually installed by light press-fitting and locked in place with cone-pointed set screws.

### PRECAUTION:

When shrink fitting of the bearing is required, chilling must be achieved by gradual cooling to not more than minus 20°F(-28°C) using freezer or regular ice (**DO NOT DRY ICE**). NOTE: Pounding or shocking the bearing while in the chilled state could cause the rubber to separate from the shell.

**Approved Bearings:** Johnson Cutless® Naval Brass Sleeve Bearings meet military specification MIL-DTL-17901C (SH) Class II Full-Molded type and have full type approval from The American Bureau of Shipping.

NAVAL BRASS SLEEVE - INCH

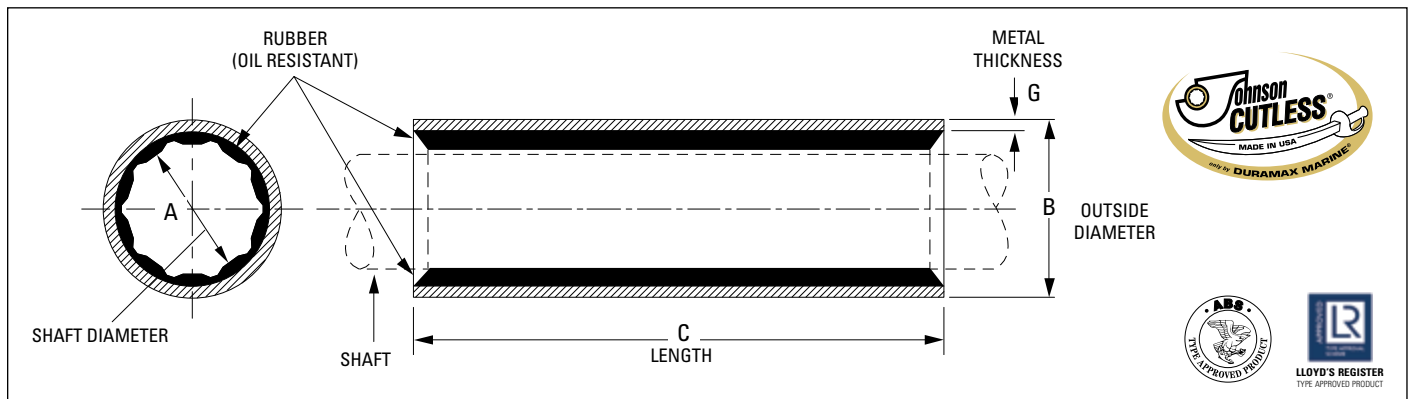

Part Number	Code	A Shaft Diameter		B Outside Diameter		C Length		G Metal Thickness		Gross Wt.	
		inches	mm	inches	mm	inches	mm	inches	mm	lb.	kg.
870192100	ABLE	3/4	19.05	1 1/4	31.75	3	76.20	1/8	3.18	0.5	0.2
870222100	* ACID	7/8	22.23	1 1/4	31.75	3 1/2	88.90	1/16	1.59	0.4	0.2
870222101	APEX	7/8	22.23	1 3/8	34.93	3 1/2	88.90	1/8	3.18	0.7	0.3
870222102	ATOM	7/8	22.23	1 1/2	38.10	3 1/2	88.90	1/8	3.18	0.8	0.4
870252100	* BACK	1	25.40	1 1/4	31.75	4	101.60	1/16	1.59	0.4	0.2
870252144	* BADE	1	25.40	1 1/4	31.75	6	152.40	1/16	1.59	0.6	0.3
870252101	BAIT	1	25.40	1 3/8	34.93	4	101.60	1/16	1.59	0.5	0.2
870252102	BALE	1	25.40	1 1/2	38.10	4	101.60	1/8	3.18	0.7	0.3
870252103	BAND	1	25.40	1 5/8	41.28	4	101.60	1/8	3.18	0.9	0.4
870252104	BASE	1	25.40	2	50.80	4	101.60	1/8	3.18	1.3	0.6
870292100	* BEAM	1 1/8	28.58	1 1/2	38.10	4 1/2	114.30	1/16	1.59	0.6	0.3
870292101	BELT	1 1/8	28.58	1 5/8	41.28	4 1/2	114.30	1/8	3.18	1.0	0.5
870292102	BEND	1 1/8	28.58	1 3/4	44.45	4 1/2	114.30	1/8	3.18	1.1	0.5
870292103	BILL	1 1/8	28.58	2	50.80	4 1/2	114.30	1/8	3.18	1.4	0.6
870322100	* BIND	1 1/4	31.75	1 1/2	38.10	5	127.00	1/16	1.59	0.6	0.3
870322101	BIRD	1 1/4	31.75	1 3/4	44.45	5	127.00	1/8	3.18	1.2	0.5
870322102	BITE	1 1/4	31.75	2	50.80	5	127.00	1/8	3.18	1.5	0.7
870322103	BLOW	1 1/4	31.75	2 1/8	53.98	5	127.00	1/8	3.18	1.7	0.8
870352100	BOAT	1 3/8	34.93	1 7/8	47.63	5 1/2	139.70	1/8	3.18	1.4	0.6
870352101	BOLD	1 3/8	34.93	2	50.80	5 1/2	139.70	1/8	3.18	1.5	0.7
870352102	BOND	1 3/8	34.93	2 1/8	53.98	5 1/2	139.70	1/8	3.18	1.8	0.8
870352103	BOOT	1 3/8	34.93	2 3/8	60.33	5 1/2	139.70	1/8	3.18	1.8	0.8
870382100	BOSS	1 1/2	38.10	2	50.80	6	152.40	1/8	3.18	1.6	0.7
870382101	BRAD	1 1/2	38.10	2 3/8	60.33	6	152.40	1/8	3.18	2.2	1.0
870412100	BREW	1 5/8	41.28	2 1/8	53.98	6 1/2	165.10	1/8	3.18	2.0	1.9
870412101	BRIM	1 5/8	41.28	2 5/8	66.68	6 1/2	165.10	1/8	3.18	2.6	1.2
870452100	BROW	1 3/4	44.45	2 3/8	60.33	7	177.80	1/8	3.18	2.3	1.0

All Bearings Shown Are Carried in Stock

\*Slimline Bearing

Part Number	Code	A Shaft Diameter		B Outside Diameter		C Length		G Metal Thickness		Gross Wt.	
		inches	mm	inches	mm	inches	mm	inches	mm	lb.	kg.
870452102	BRUT	1 3/4	44.45	2 1/2	63.50	7	177.80	3/32	2.38	2.5	1.1
870452101	BUCK	1 3/4	44.45	2 5/8	66.68	7	177.80	1/8	3.18	2.8	1.3
870482100	BULB	1 7/8	47.63	2 5/8	66.68	7 1/2	190.50	1/8	3.18	2.8	1.3
870482101	BULL	1 7/8	47.63	2 15/16	74.61	7 1/2	190.50	3/32	2.38	3.1	1.4
870512100	CALL	2	50.80	2 5/8	66.68	8	203.20	1/8	3.18	2.8	1.3
870512143	CAMP	2	50.80	2 3/4	69.85	8	203.20	1/8	3.18	3.3	1.5
870512101	CALM	2	50.80	3	76.20	8	203.20	1/8	3.18	3.8	1.7
870542100	CAME	2 1/8	53.98	2 15/16	74.61	8 1/2	215.90	1/8	3.18	3.1	1.4
870542101	CAPE	2 1/8	53.98	3 1/8	79.38	8 1/2	215.90	1/8	3.18	4.1	1.9
870572100	CARE	2 1/4	57.15	2 15/16	74.61	9	228.60	3/32	2.38	3.1	1.4
870572133	CARD	2 1/4	57.15	3	76.20	9	228.60	1/8	3.18	3.9	1.8
870572101	CART	2 1/4	57.15	3 1/8	79.38	9	228.60	1/8	3.18	4.3	2.0
870572102	CASE	2 1/4	57.15	3 3/8	85.73	9	228.60	1/8	3.18	5.1	2.3
870602100	COOK	2 3/8	60.33	3 3/8	85.73	9 1/2	241.30	1/8	3.18	4.8	2.2
870642100	CORD	2 1/2	63.50	3 1/8	79.38	10	254.00	1/8	3.18	4.5	2.0
870642174	CORK	2 1/2	63.50	3 1/4	82.55	10	254.00	1/16	1.59	3.1	1.4
870642101	CORN	2 1/2	63.50	3 3/8	85.73	10	254.00	1/8	3.18	5.1	2.3
870642134	COVE	2 1/2	63.50	3 1/2	88.90	10	254.00	5/32	3.97	6.6	3.0
870672100	CRAB	2 5/8	66.68	3 3/8	85.73	10 1/2	266.70	1/8	3.18	5.2	2.4
870702100	CROW	2 3/4	69.85	3 3/8	85.73	11	279.40	1/8	3.18	4.8	2.2
870702139	CUBE	2 3/4	69.85	3 1/2	88.90	11	279.40	5/32	3.97	6.6	3.0
870702101	CURD	2 3/4	69.85	3 3/4	95.25	11	279.40	1/8	3.18	6.6	3.0
870732100	CURE	2 7/8	73.03	3 3/4	95.25	11 1/2	292.10	1/8	3.18	6.5	2.9
870762100	DANE	3	76.20	3 3/4	95.25	12	304.80	1/8	3.18	6.8	3.1
870762101	DARE	3	76.20	4	101.60	12	304.80	1/8	3.18	7.7	3.5
870802100	DARK	3 1/8	79.38	4 1/4	107.95	12 1/2	317.50	1/8	3.18	8.6	3.9
870832100	DARN	3 1/4	82.55	4	101.60	13	330.20	1/8	3.18	7.8	3.5
870832101	DELL	3 1/4	82.55	4 1/4	107.95	13	330.20	1/8	3.18	8.7	3.9
870862100	DIKE	3 3/8	85.73	4 1/2	114.30	13 1/2	342.90	1/8	3.18	10.2	4.6
870892100	DINE	3 1/2	88.90	4 1/4	107.95	14	355.60	1/8	3.18	8.9	4.0
870892101	DOCK	3 1/2	88.90	4 1/2	114.30	14	355.60	1/8	3.18	10.3	4.7
870922100	DOLE	3 5/8	92.08	4 1/2	114.30	14 1/2	368.30	1/8	3.18	10.0	4.5
870952100	DONE	3 3/4	95.25	4 1/2	114.30	15	381.00	1/8	3.18	9.6	4.4
870952101	DOVE	3 3/4	95.25	5	127.00	15	381.00	3/16	4.76	16.5	7.5
870952102	DRAW	3 3/4	95.25	5 1/4	133.35	15	381.00	3/16	4.76	18.2	8.3
870992100	DULL	3 7/8	98.43	5 1/4	133.35	15 1/2	393.70	3/16	4.76	18.7	8.5
871022100	EARN	4	101.60	5	127.00	16	406.40	3/16	4.76	16.9	7.7
871022101	EASE	4	101.60	5 1/4	133.35	16	406.40	3/16	4.76	18.7	8.5
871052100	ECHO	4 1/8	104.78	5 1/4	133.35	16 1/2	419.10	3/16	4.76	19.0	8.6
871082100	EDIT	4 1/4	107.95	5 1/2	139.70	17	431.80	3/16	4.76	22.0	10.0
871112100	ELSE	4 3/8	111.13	5 3/4	146.05	17 1/2	444.50	3/16	4.76	23.7	10.8
871152100	EPIC	4 1/2	114.30	5 1/2	139.70	18	457.20	3/16	4.76	21.3	9.7
871152101	EDGE	4 1/2	114.30	5 3/4	146.05	18	457.20	3/16	4.76	23.7	10.8
871182100	EVEN	4 5/8	117.48	6 1/8	155.58	18 1/2	469.90	1/4	6.35	42.0	19.1
871212100	EVER	4 3/4	120.65	6 1/8	155.58	19	482.60	1/4	6.35	41.0	18.6
871242100	EVIL	4 7/8	123.83	6 1/8	155.58	19 1/2	495.30	1/4	6.35	41.7	18.9
871272100	FACE	5	127.00	6 1/8	155.58	20	508.00	1/4	6.35	42.3	19.2
871272101	FACT	5	127.00	6 1/2	165.10	20	508.00	1/4	6.35	48.7	22.1
871342100	FADE	5 1/4	133.35	6 3/4	171.45	21	533.40	1/4	6.35	50.3	22.8
871342101	FARE	5 1/4	133.35	7	177.80	21	533.40	1/4	6.35	55.0	24.9
871372100	FEAR	5 3/8	136.53	6 3/4	171.45	21 1/2	546.10	1/4	6.35	51.3	23.3
871372101	FELT	5 3/8	136.53	7	177.80	21 1/2	546.10	1/4	6.35	56.0	25.4
871402100	FIND	5 1/2	139.70	7	177.80	22	558.80	1/4	6.35	56.0	25.4
871402181	FLAG	5 1/2	139.70	7 1/4	184.15	22	558.80	3/8	9.53	58.2	26.4
871432100	FLAT	5 5/8	142.88	7	177.80	22 1/2	571.50	1/4	6.35	55.5	25.2
871462100	FORK	5 3/4	146.05	7	177.80	23	584.20	1/4	6.35	56.5	25.6
871502100	FUEL	5 7/8	149.23	7 1/2	190.50	24	609.60	1/4	6.35	65.8	29.8
871532100	GALE	6	152.40	7 1/2	190.50	24	609.60	1/4	6.35	66.0	29.9
871662100	GOLD	6 1/2	165.10	8 3/8	212.73	30	762.00	7/16	11.11	150.0	68.0

All Bearings Shown Are Carried in Stock

# Naval Brass Sleeve Bearings

## METRIC SIZE SERIES



Johnson Cutless® Naval Brass Sleeve Bearings adapt equally well to strut and stern-tube mounts, and are often used effectively as rudder-stock and pintle bushings. Bearing diameters are precision fitted to the designated shaft size with the correct clearance for efficient water lubrication. External brass shells are machined and polished to provide easy fitting. Specially formulated oil and chemical resistant nitrile rubber is securely bonded to the shell. Units with thin shells are available for the struts of small craft. Sleeve Bearings are usually installed by light press-fitting and locked in place with cone-pointed set screws.

### PRECAUTION:

When shrink fitting of the bearing is required, chilling must be achieved by gradual cooling to not more than minus 20°F(-28°C) using freezer or regular ice (**DO NOT DRY ICE**). NOTE: Pounding or shocking the bearing while in the chilled state could cause the rubber to separate from the shell.

**Approved Bearings:** Johnson Cutless® Naval Brass Sleeve Bearings meet military specification MIL-DTL-17901C (SH) Class II Full-Molded type and have full type approval from The American Bureau of Shipping.

NAVAL BRASS SLEEVE - METRIC

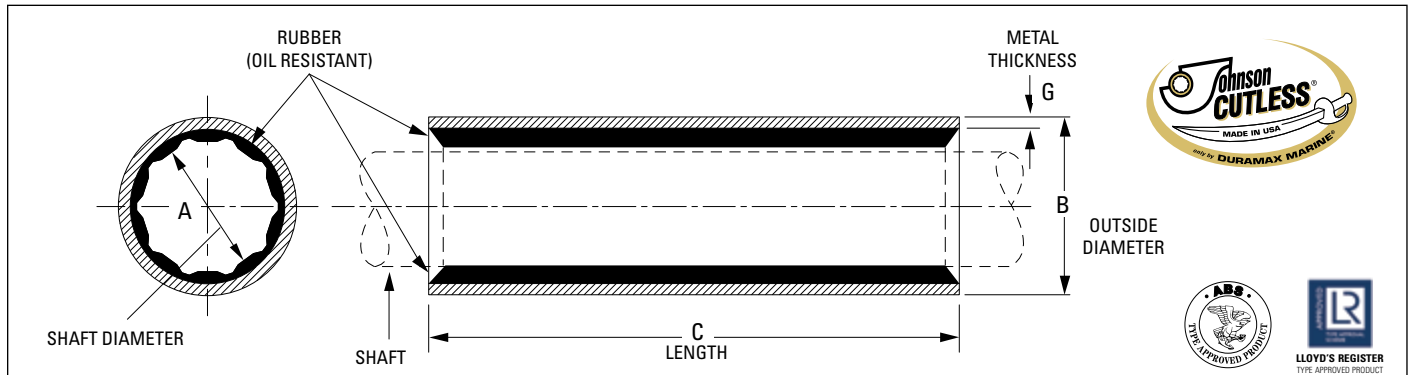

Part Number	A Shaft Diameter mm	B Outside Diameter mm	C Length mm	G Metal Thickness mm	Gross Wt.	
					lb.	kg.
870254100	25	40	100	2.54	0.8	0.4
870284100	28	42	112	2.35	0.7	0.3
870304100	30	45	120	3.07	1.2	0.5
870324100	32	45	128	3.07	1.3	0.6
870354100	35	50	140	3.07	1.5	0.7
870384100	38	55	152	3.07	1.7	0.8
870404100	40	55	160	3.07	1.8	0.8
870454100	45	65	180	3.30	2.8	1.3
870504100	50	70	200	3.26	3.1	1.4
870554100	55	75	220	2.58	3.8	1.7
870604100	60	80	240	3.26	4.5	2.0
870654100	65	85	260	2.82	4.8	2.2
870704100	70	90	280	4.76	5.8	2.6
870754100	75	95	300	3.05	6.7	3.0
870804100	80	100	320	3.17	7.7	3.5
870854100	85	105	340	3.19	8.7	3.9
870904100	90	110	360	4.78	12.5	5.7
870954100	95	115	380	4.51	13.3	6.0
871004100	100	125	400	3.77	14.3	6.5
871054100	105	130	420	4.52	17.6	8.0
871104100	110	135	440	4.51	19.0	8.6
871154100	115	145	460	4.25	25.3	11.0
871204100	120	155	480	6.06	31.6	14.0
871304100	130	170	520	5.63	49.0	22.0
871404100	140	180	560	7.45	56.0	25.0

# Non-Metallic Sleeve Bearings

## METRIC SIZE SERIES



Johnson Cutless® Non-Metallic Sleeve Bearings feature a dense structure of engineered reinforced thermoset plastic. The specially compounded Nitrile Rubber is securely bonded to the shell with all tolerances maintained for proper lubrication. Being non-corrosive and inherently resistant to all known chemicals, oil and grease, as well as being anti-electrolytic, the Johnson Cutless® Non-Metallic Sleeve Bearings are ideally suited for installations wherever corrosion or electrolysis is a problem.

### PRECAUTION:

When shrink fitting of the bearing is required, chilling must be achieved by gradual cooling to not more than minus 20°F (-28°C) using freezer or regular ice (**DO NOT DRY ICE**). NOTE: Pounding or shocking the bearing while in the chilled state could cause the rubber to separate from the shell.

**Approved Bearings:** Johnson Cutless Non-Metallic Sleeve Bearings have full type approval from The American Bureau of Shipping.

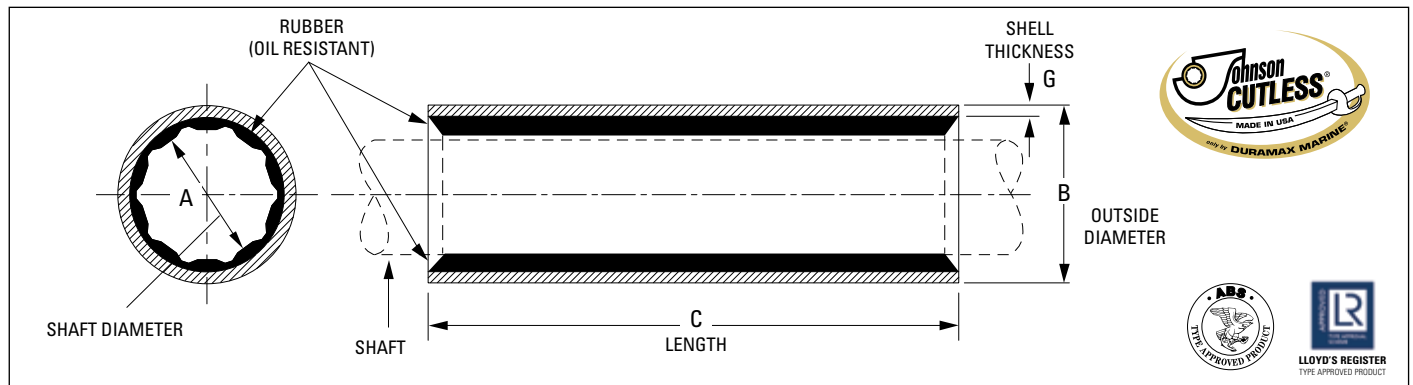

Part Number	A Shaft Diameter mm	B Outside Diameter mm	C Length mm	G Shell Thickness mm	Gross Wt.	
					lb.	kg.
870255700	25	40	100	2.54	0.3	0.1
870285700	28	42	112	2.35	0.4	0.2
870305700	30	45	120	3.07	0.4	0.2
870325700	32	45	128	3.07	0.5	0.2
870355700	35	50	140	3.07	0.5	0.2
870385700	38	55	152	3.07	0.6	0.3
870405700	40	55	160	3.07	0.6	0.3
870455700	45	65	180	3.30	0.9	0.4
870505700	50	70	200	3.25	1.1	0.5
870555700	55	75	220	2.58	1.3	0.6
870605700	60	80	240	3.25	1.6	0.7
870655700	65	85	260	2.81	1.8	0.8
870705700	70	90	280	4.75	2.0	0.9
870755700	75	95	300	3.05	2.5	1.1
870805700	80	100	320	3.16	2.6	1.2
870855700	85	105	340	3.17	3.0	1.4
870905700	90	110	360	4.76	3.4	1.5
870955700	95	115	380	4.50	4.0	1.8
871005700	100	125	400	3.76	4.6	2.1
871055700	105	130	420	4.51	5.2	2.4
871105700	110	135	440	4.51	6.0	2.7
871155700	115	145	460	4.24	7.6	3.4
871205700	120	155	480	6.06	8.6	3.9
871305700	130	170	520	5.63	13.0	5.9

# Non-Metallic Sleeve Bearings

## INCH SIZE SERIES



Johnson Cutless® Non-Metallic Sleeve Bearings feature a dense structure of engineered reinforced thermoset plastic. The specially compounded Nitrile Rubber is securely bonded to the shell with all tolerances maintained for proper lubrication. Being non-corrosive and inherently resistant to all known chemicals, oil and grease, as well as being anti-electrolytic, the Johnson Cutless® Non-Metallic Sleeve Bearings are ideally suited for installations wherever corrosion or electrolysis is a problem.

### PRECAUTION:

When shrink fitting of the bearing is required, chilling must be achieved by gradual cooling to not more than minus 20°F(-28°C) using freezer or regular ice (**DO NOT DRY ICE**). NOTE: Pounding or shocking the bearing while in the chilled state could cause the rubber to separate from the shell.

**Approved Bearings:** Johnson Cutless Non-Metallic Sleeve Bearings have full type approval from The American Bureau of Shipping.

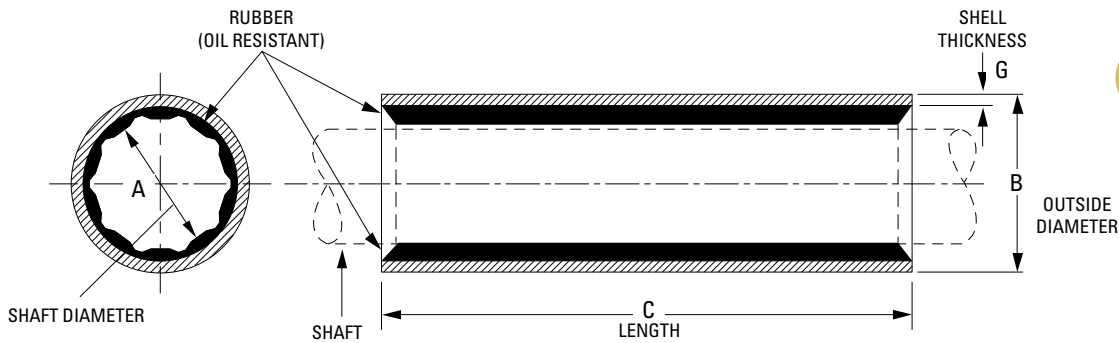

Part Number	Code	A		B		C		G		Gross Wt.	
		Shaft Diameter inches	mm	Outside Diameter inches	mm	Length inches	mm	Shell Thickness inches	mm	lb.	kg.
870193700	ALDA	3/4	19.05	1 1/4	31.75	3	76.20	1/8	3.18	0.2	0.1
870223700	ALICE	7/8	22.23	1 1/4	31.75	3 1/2	88.90	1/16	1.59	0.2	0.1
870223701	ANNE	7/8	22.23	1 3/8	34.93	3 1/2	88.90	1/8	3.18	0.2	0.1
870223702	ARDELE	7/8	22.23	1 1/2	38.10	3 1/2	88.90	1/8	3.18	0.3	0.1
870253700	BABE	1	25.40	1 1/4	31.75	4	101.60	1/16	1.59	0.2	0.1
870253701	BECKY	1	25.40	1 3/8	34.93	4	101.60	1/16	1.59	0.2	0.1
870253702	BETTY	1	25.40	1 1/2	38.10	4	101.60	1/8	3.18	0.3	0.1
870253703	CANDY	1	25.40	1 5/8	41.28	4	101.60	1/8	3.18	0.3	0.1
870253704	CARLA	1	25.40	2	50.80	4	101.60	1/8	3.18	0.5	0.2
870293700	CEIL	1 1/8	28.58	1 1/2	38.10	4 1/2	114.30	1/16	1.59	0.3	0.1
870293701	CINDY	1 1/8	28.58	1 5/8	41.28	4 1/2	114.30	1/8	3.18	0.3	0.1
870293702	CONNIE	1 1/8	28.58	1 3/4	44.45	4 1/2	114.30	1/8	3.18	0.4	0.2
870293703	CORA	1 1/8	28.58	2	50.80	4 1/2	114.30	1/16	1.59	0.5	0.2
870323700	DEENA	1 1/4	31.75	1 1/2	38.10	5	127.00	3/64	1.19	0.2	0.1
870323701	DELLA	1 1/4	31.75	1 3/4	44.45	5	127.00	1/8	3.18	0.4	0.2
870323702	DORIS	1 1/4	31.75	2	50.80	5	127.00	1/8	3.18	0.6	0.3
870323703	DOTTY	1 1/4	31.75	2 1/8	53.98	5	127.00	1/8	3.18	0.6	0.3
870353700	EDNA	1 3/8	34.93	1 7/8	47.63	5 1/2	139.70	1/8	3.18	0.4	0.2
870353701	ELLEN	1 3/8	34.93	2	50.80	5 1/2	139.70	1/8	3.18	0.5	0.2
870353702	ELSA	1 3/8	34.93	2 1/8	53.98	5 1/2	139.70	1/8	3.18	0.6	0.3
870353703	ERMA	1 3/8	34.93	2 3/8	60.33	5 1/2	139.70	1/8	3.18	0.9	0.4
870383700	EVA	1 1/2	38.10	2	50.80	6	152.40	1/8	3.18	0.5	0.2
870383701	FANNY	1 1/2	38.10	2 3/8	60.33	6	152.40	1/8	3.18	0.9	0.4
870413700	FLO	1 5/8	41.28	2 1/8	53.98	6 1/2	165.10	1/8	3.18	0.6	0.3
870413701	FRAN	1 5/8	41.28	2 5/8	66.68	6 1/2	165.10	1/8	3.18	1.1	0.5

All Bearings Shown Are Carried in Stock



Part Number	Code	A Shaft Diameter		B Outside Diameter		C Length		G Shell Thickness		Gross Wt.	
		inches	mm	inches	mm	inches	mm	inches	mm	lb.	kg.
870453700	GLENDA	1 3/4	44.45	2 3/8	60.33	7	177.80	1/8	3.18	0.7	0.3
870453702	GLENNIS	1 3/4	44.45	2 1/2	63.50	7	177.80	3/32	2.38	0.8	0.4
870453701	GLORIA	1 3/4	44.45	2 5/8	66.68	7	177.80	1/8	3.18	0.9	0.4
870483700	GWEN	1 7/8	47.63	2 5/8	66.68	7 1/2	190.50	1/8	3.18	0.8	0.4
870483701	HANNA	1 7/8	47.63	2 15/16	74.61	7 1/2	190.50	3/32	2.38	1.5	0.7
870513700	HAZEL	2	50.80	2 5/8	66.68	8	203.20	1/8	3.18	0.8	0.4
870513701	HELEN	2	50.80	3	76.20	8	203.20	1/8	3.18	1.5	0.7
870543700	HILDA	2 1/8	53.98	2 15/16	74.61	8 1/2	215.90	1/8	3.18	1.3	0.6
870543701	ILA	2 1/8	53.98	3 1/8	79.38	8 1/2	215.90	1/8	3.18	1.6	0.7
870573700	INEZ	2 1/4	57.15	2 15/16	74.61	9	228.60	3/32	2.38	1.2	0.5
870573701	INGRID	2 1/4	57.15	3 1/8	79.38	9	228.60	1/8	3.18	1.4	0.6
870573702	IRENE	2 1/4	57.15	3 3/8	85.73	9	228.60	1/8	3.18	1.6	0.7
870573735	IRIS	2 1/4	57.15	3	76.20	9	228.60	1/8	3.18	3.9	1.8
870603700	JENNY	2 3/8	60.33	3 3/8	85.73	9 1/2	241.30	1/8	3.18	1.7	0.8
870643700	JOAN	2 1/2	63.50	3 1/8	79.38	10	254.00	1/8	3.18	1.4	0.6
870643701	JOSIE	2 1/2	63.50	3 3/8	85.73	10	254.00	1/8	3.18	2.0	0.9
870673700	JOYCE	2 5/8	66.68	3 3/8	85.73	10 1/2	266.70	1/8	3.18	1.8	0.8
870703700	JUNE	2 3/4	69.85	3 3/8	85.73	11	279.40	1/8	3.18	1.6	0.7
870703701	KATHY	2 3/4	69.85	3 3/4	95.25	11	279.40	1/8	3.18	2.6	1.2
870733700	KELLY	2 7/8	73.03	3 3/4	95.25	11 1/2	292.10	1/8	3.18	2.5	1.1
870763700	KIM	3	76.20	3 3/4	95.25	12	304.80	1/8	3.18	2.4	1.1
870763701	LAURA	3	76.20	4	101.60	12	304.80	1/8	3.18	3.1	1.4
870803700	LENA	3 1/8	79.38	4 1/4	107.95	12 1/2	317.50	1/8	3.18	3.8	1.7
870833700	LINDA	3 1/4	82.55	4	101.60	13	330.20	1/8	3.18	2.7	1.2
870833701	LISA	3 1/4	82.55	4 1/4	107.95	13	330.20	1/8	3.18	3.5	1.6
870863700	LOIS	3 3/8	85.73	4 1/2	114.30	13 1/2	342.90	1/8	3.18	4.3	2.0
870893700	MANDY	3 1/2	88.90	4 1/4	107.95	14	355.60	1/8	3.18	3.1	1.4
870893701	MARIE	3 1/2	88.90	4 1/2	114.30	14	355.60	1/8	3.18	4.1	1.9
870923700	MARTHA	3 5/8	92.08	4 1/2	114.30	14 1/2	368.30	1/8	3.18	3.7	1.7
870953700	MARY	3 3/4	95.25	4 1/2	114.30	15	381.00	1/8	3.18	3.5	1.6
870953701	NANCY	3 3/4	95.25	5	127.00	15	381.00	3/16	4.76	5.9	2.7
870953702	NEVA	3 3/4	95.25	5 1/4	133.35	15	381.00	3/16	4.76	7.4	3.4
870993700	NORA	3 7/8	98.43	5 1/4	133.35	15 1/2	393.70	3/16	4.76	6.4	2.9
871023700	OLGA	4	101.60	5	127.00	16	406.40	3/16	4.76	5.3	2.4
871023701	OLIVE	4	101.60	5 1/4	133.35	16	406.40	3/16	4.76	6.4	2.9
871053700	OPAL	4 1/8	104.78	5 1/4	133.35	16 1/2	419.10	3/16	4.76	6.3	2.9
871083700	PAM	4 1/4	107.95	5 1/2	139.70	17	431.80	3/16	4.76	8.3	3.8
871113700	PANSY	4 3/8	111.13	5 3/4	146.05	17 1/2	444.50	3/16	4.76	8.8	4.0
871153700	PAULA	4 1/2	114.30	5 1/2	139.70	18	457.20	3/16	4.76	7.3	3.3
871153701	PENNY	4 1/2	114.30	5 3/4	146.05	18	457.20	3/16	4.76	8.8	4.0
871183700	RHODA	4 5/8	117.48	6 1/8	155.58	18 1/2	469.90	1/4	6.35	11.3	5.1
871213700	RINA	4 3/4	120.65	6 1/8	155.58	19	482.60	1/4	6.35	11.0	5.0
871243700	ROSE	4 7/8	123.83	6 1/8	155.58	19 1/2	495.30	1/4	6.35	10.3	4.7
871273700	RUTH	5	127.00	6 1/8	155.58	20	508.00	1/4	6.35	9.5	4.3
871273701	SALLY	5	127.00	6 1/2	165.10	20	508.00	1/4	6.35	13.0	5.9
871343700	SANDRA	5 1/4	133.35	6 3/4	171.45	21	533.40	1/4	6.35	14.0	6.4
871343701	SARAN	5 1/4	133.35	7	177.80	21	533.40	1/4	6.35	16.0	7.3
871373700	SUSAN	5 3/8	136.53	6 3/4	171.45	21 1/2	546.10	1/4	6.35	12.8	5.8
871373701	TONI	5 3/8	136.53	7	177.80	21 1/2	546.10	1/4	6.35	15.8	7.2
871403700	TRICIA	5 1/2	139.70	7	177.80	22	558.80	1/4	6.35	14.8	6.7
871433700	VERA	5 5/8	142.88	7	177.80	22 1/2	571.50	1/4	6.35	14.0	6.4
871463700	WANDA	5 3/4	146.05	7	177.80	23	584.20	1/4	6.35	14.8	6.7
871503700	WINNIE	5 7/8	149.23	7 1/2	190.50	24	609.60	1/4	6.35	18.0	8.2
871533700	ZELDA	6	152.40	7 1/2	190.50	24	609.60	1/4	6.35	18.8	8.5

All Bearings Shown Are Carried in Stock

# Solid Naval Brass Flanged Bearings

## STRUT OR AFT STERN TUBE

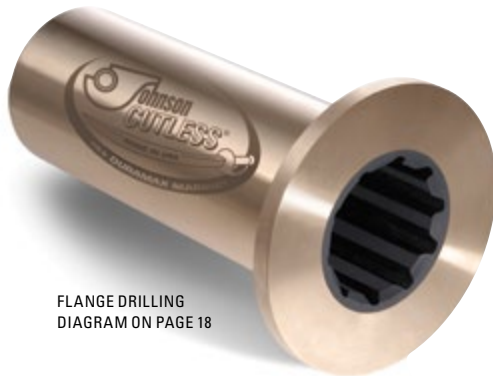

FLANGE DRILLING  
DIAGRAM ON PAGE 18

**Johnson Cutless® Flanged Bearings** are centrifugally cast naval brass with an integral flange for bolting to stern tube or strut housing to retain bearing and prevent rotation in housing. Specially formulated oil and chemical resistant nitrile rubber is securely bonded to the shell. Shells are heavy walled providing structural strength and can be step turned if desired. Flanges are furnished UN-DRILLED unless specified. See page 18 for Drilling Diagrams. For Split and Stepped Styles see pages 14-17.

### PRECAUTION:

When shrink fitting of the bearing is required, chilling must be achieved by gradual cooling to not more than minus 20°F(-28°C) using freezer or regular ice (DO NOT DRY ICE). NOTE: Pounding or shocking the bearing while in the chilled state could cause the rubber to separate from the shell.

Approved Bearings: Johnson Cutless® Naval Brass Flanged Bearings meet military specification MIL-DTL-17901C (SH) Class II Full-Molded type and have full type approval from The American Bureau of Shipping.

Part No.	Code	A Shaft Diameter		B Outside Diameter		C Length		D Flange Diameter		E Flange Thickness		F Metal I.D.		G Metal Thickness		Gross Wt.	
		inch	mm	inch	mm	inch	mm	inch	mm	inch	mm	inch	mm	inch	mm	lbs.	kg.
860512102	BRACE	2	50.80	3	76.20	8	203.20	5	127.00	3/8	9.53	25/8	66.68	3/16	4.76	7	3.2
860642100	BROAD	2 1/2	63.50	3 3/8	85.73	10	254.00	5 1/2	139.70	3/8	9.53	3 1/8	79.38	1/8	3.18	9	4.1
860762100	CATCH	3	76.20	4 1/4	107.95	12	304.80	6 3/4	171.45	1/2	12.70	3 3/4	95.25	1/4	6.35	20	9.1
860832100	CLAMP	3 1/4	82.55	4 1/2	114.30	13	330.20	7	177.80	1/2	12.70	4	101.60	1/4	6.35	22	10.0
860892100	CRANK	3 1/2	88.90	4 3/4	120.65	12 1/2	317.50	6 3/4	171.45	1/2	12.70	4 1/4	107.95	1/4	6.35	21	9.5
860892101	CLEAR	3 1/2	88.90	4 7/8	123.83	14	355.60	7 3/8	187.33	1/2	12.70	4 1/4	107.95	5/16	7.94	29	13.2
860952100	CIVIL	3 3/4	95.25	5 1/4	133.35	15	381.00	7 3/4	196.85	1/2	12.70	4 5/8	117.48	5/16	7.94	32	14.5
861022100	DRAFT	4	101.60	5 1/2	139.70	16	406.40	8	203.20	1/2	12.70	4 7/8	123.83	5/16	7.94	36	16.3
861082100	DREAD	4 1/4	107.95	5 3/4	146.05	17	431.80	8 1/4	209.55	1/2	12.70	5 1/8	130.18	5/16	7.94	48	21.8
861112100	DANCE	4 3/8	111.13	6	152.40	22	558.80	8 7/8	225.43	1/2	12.70	5 3/8	136.53	5/16	7.94	64	29.0
861152100	DRINK	4 1/2	114.30	6	152.40	18	457.20	8 7/8	225.43	1/2	12.70	5 3/8	136.53	5/16	7.94	56	25.4
861212100	DROVE	4 3/4	120.65	6 1/4	158.75	19	482.60	9 1/8	231.78	1/2	12.70	5 5/8	142.88	5/16	7.94	62	28.1
861272100	EARTH	5	127.00	6 3/4	171.45	20	508.00	9 5/8	244.48	9/16	14.29	6	152.40	3/8	9.53	76	34.5
861342100	EASEL	5 1/4	133.35	6 7/8	174.63	21	533.40	9 7/8	250.83	9/16	14.29	6 1/8	155.58	3/8	9.53	81	36.7
861402100	ERASE	5 1/2	139.70	7 1/4	184.15	22	558.80	10 1/4	260.35	9/16	14.29	6 1/2	165.10	3/8	9.53	86	39.0
861462100	EVENT	5 3/4	146.05	7 1/4	184.15	23	584.20	10 1/4	260.35	9/16	14.29	6 1/2	165.10	3/8	9.53	88	39.9
861532100	FABLE	6	152.40	7 3/4	196.85	15	381.00	12 1/4	311.15	9/16	14.29	6 1/2	165.10	3/8	9.53	75	34.0
861532101	FAULT	6	152.40	7 3/4	196.85	24	609.60	11	279.40	9/16	14.29	7	177.80	3/8	9.53	101	45.8
861592100	FENCE	6 1/8	155.58	7 7/8	200.03	22	558.80	10 1/2	266.70	9/16	14.29	7	177.80	3/8	9.53	—	—
861592100	---	6 1/4	158.75	8	203.20	22 1/2	571.50	10 5/8	269.88	9/16	14.29	7 1/8	180.98	3/8	9.53	97	44.0
861592100	---	6 3/8	161.93	8 1/8	206.38	23	584.20	10 3/4	273.05	9/16	14.29	7 1/4	184.15	3/8	9.53	—	—
861662100	FLARE	6 1/2	165.10	8 3/8	212.73	23 1/2	596.90	11	279.40	9/16	14.29	7 3/8	187.33	7/16	11.11	113	51.3
861662101	FLEET	6 1/2	165.10	8 3/8	212.73	30	762.00	11	279.40	5/8	15.88	7 1/2	190.50	7/16	11.11	141	64.0
861692100	FLUTE	6 5/8	168.28	8 1/2	215.90	15	381.00	13 1/2	342.90	5/8	15.88	7 1/2	190.50	7/16	11.11	100	45.4
861692101	FLOOR	6 5/8	168.28	8 1/2	215.90	24	609.60	11 1/4	285.75	9/16	14.29	7 5/8	193.68	7/16	11.11	133	60.3
861692103	FRANK	6 5/8	168.28	8 5/8	219.08	24	609.60	11 1/4	285.75	9/16	14.29	7 5/8	193.68	3/8	9.53	130	59.0
861722100	FROZE	6 3/4	171.45	8 3/4	222.25	24	609.60	11 1/4	285.75	5/8	15.88	7 7/8	200.03	7/16	11.11	127	57.6
861722101	FANCY	6 3/4	171.45	8 3/4	222.25	24 1/2	622.30	11 3/8	288.93	9/16	14.29	7 7/8	200.03	7/16	11.11	135	61.2
861752100	FOUND	6 7/8	174.63	8 7/8	225.43	24 1/2	622.30	11 3/8	288.93	9/16	14.29	7 7/8	200.03	1/2	12.70	134	60.8
861752101	---	6 7/8	174.63	8 7/8	225.43	25	635.00	11 1/2	292.10	9/16	14.29	8	203.20	3/16	4.76	—	—
861782100	GAVEL	7	177.80	9	228.60	25 1/2	647.70	11 5/8	295.28	9/16	14.29	8 1/8	206.38	7/16	11.11	140	63.5
861782101	GLAND	7	177.80	9 1/8	231.78	25 1/2	647.70	11 5/8	295.28	9/16	14.29	8 1/8	206.38	1/2	12.70	154	69.9
861782101	---	7 1/8	180.98	9 1/8	231.78	25 1/2	647.70	11 3/4	298.45	9/16	14.29	8 1/4	209.55	7/16	11.11	—	—
861852100	GLASS	7 1/4	184.15	9 1/4	234.95	26 1/2	673.10	11 7/8	301.63	9/16	14.29	8 3/8	212.73	7/16	11.11	150	68.0
861852100	---	7 3/8	187.33	9 1/2	241.30	27	685.80	12 1/8	307.98	9/16	14.29	8 5/8	219.08	7/16	11.11	—	—
861912100	GLORY	7 1/2	190.50	9 5/8	244.48	17 1/2	444.50	14 1/2	368.30	1	25.40	8 3/4	222.25	7/16	11.11	129	58.5
861912101	GLOBE	7 1/2	190.50	9 5/8	244.48	27 1/2	698.50	12 3/4	323.85	9/16	14.29	8 3/4	222.25	7/16	11.11	160	72.6
861912101	---	7 5/8	193.68	9 3/4	247.65	28	711.20	12 3/8	314.33	9/16	14.29	8 3/4	222.25	1/2	12.70	—	—
861972100	GIPSY	7 3/4	196.85	9 7/8	250.83	28 1/2	723.90	12 1/2	317.50	9/16	14.29	8 7/8	225.43	1/2	12.70	180	81.6
861972100	---	7 7/8	200.03	10	254.00	29 1/2	749.30	12 5/8	320.68	9/16	14.29	9 1/8	231.78	7/16	11.11	—	—
862042101	HEART	8	203.20	10 1/4	260.35	29 1/2	749.30	13 1/4	336.55	5/8	15.88	9 1/2	241.30	3/8	9.53	166	75.3
862042102	HEDGE	8	203.20	10 1/2	266.70	29 1/2	749.30	13 1/4	336.55	5/8	15.88	9 1/2	241.30	1/2	12.70	210	95.3
862042102	---	8 1/8	206.38	10 3/8	263.53	30	762.00	13 3/8	339.73	5/8	15.88	9 3/8	238.13	1/2	12.70	—	—
862102100	HITCH	8 1/4	209.55	10 1/2	266.70	30 1/2	774.70	13 1/2	342.90	5/8	15.88	9 1/2	241.30	1/2	12.70	208	94.3
862102100	---	8 3/8	212.73	10 5/8	269.88	31	787.40	13 5/8	346.08	5/8	15.88	9 5/8	244.48	1/2	12.70	—	—
862172100	HOIST	8 1/2	215.90	10 3/4	273.05	31 1/2	800.10	13 3/4	349.25	5/8	15.88	9 3/4	247.65	1/2	12.70	215	97.5
862172100	---	8 5/8	219.08	10 7/8	276.23	32	812.80	13 7/8	352.43	5/8	15.88	9 7/8	250.83	1	25.40	—	—
862232100	HOVER	8 3/4	222.25	11	279.40	32 1/2	825.50	14	355.60	5/8	15.88	10	254.00	1/2	12.70	233	105.7
862292100	---	8 7/8	225.43	11 1/8	282.58	33	838.20	14 1/8	358.78	3/4	19.05	10 1/8	257.18	1/2	12.70	—	—
862292100	INFRA	9	228.60	11 1/4	285.75	33 1/2	850.90	14 1/4	361.95	3/4	19.05	10 1/4	260.35	1/2	12.70	254	115.2
862292101	IDEAL	9	228.60	11 1/2	292.10	33 3/8	847.73	15	381.00	3/4	19.05	10 1/4	260.35	5/8	15.88	301	136.5

NOTE: Dimensions for each size bearing continue across both pages.



A = SHAFT DIAMETER  
 B = OUTSIDE DIAMETER  
 C = LENGTH  
 D = FLANGE DIAMETER  
 E = FLANGE THICKNESS  
 F = METAL I.D.  
 G = METAL THICKNESS

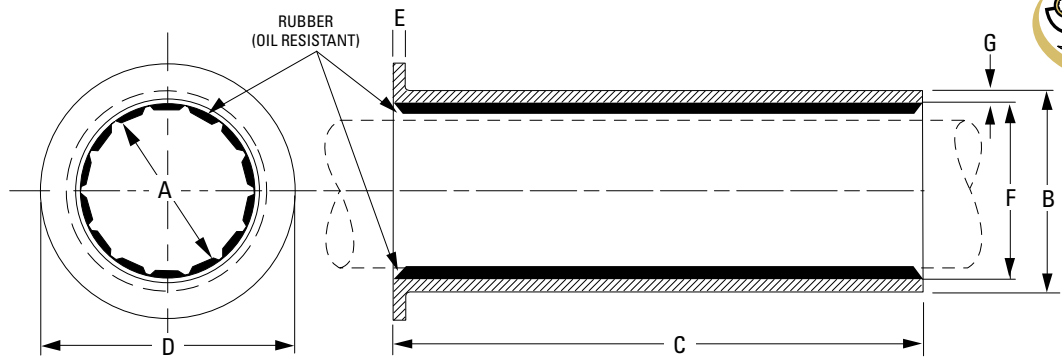

Part No.	Code	A Shaft Diameter		B Outside Diameter		C Length		D Flange Diameter		E Flange Thickness		F Metal I.D.		G Metal Thickness		Gross Wt.	
		inch	mm	inch	mm	inch	mm	inch	mm	inch	mm	inch	mm	inch	mm	lbs.	kg.
862332101	---	9 1/8	231.78	11 3/8	288.93	34	863.60	14 1/2	368.30	3/4	19.05	10 3/8	263.53	1/2	12.70	---	---
862332100	INNER	9 1/8	231.78	11 1/2	292.10	34 1/2	876.30	16 3/8	415.93	5/8	15.88	10 3/8	263.53	9/16	14.29	284	128.8
862362100	IRISH	9 1/4	234.95	11 1/2	292.10	34 1/2	876.30	14 5/8	371.48	11/16	17.46	10 1/2	266.70	1/2	12.70	260	117.9
862392100	---	9 3/8	238.13	11 5/8	295.28	35	889.00	14 3/4	374.65	3/4	19.05	10 5/8	269.88	1/2	12.70	---	---
862422100	INSET	9 1/2	241.30	11 3/4	298.45	35 1/2	901.70	14 7/8	377.83	3/4	19.05	10 3/4	273.05	1/2	12.70	274	124.3
862452100	---	9 5/8	244.48	11 7/8	301.63	36	914.40	15	381.00	3/4	19.05	10 7/8	276.23	1/2	12.70	---	---
862482100	IVORY	9 3/4	247.65	12 1/8	307.98	36 1/2	927.10	15 1/4	387.35	3/4	19.05	11	279.40	9/16	14.29	307	139.3
---	---	9 7/8	250.83	12 1/4	311.15	37	939.80	15 3/8	390.53	3/4	19.05	11 1/8	282.58	9/16	14.29	---	---
862552100	JEWEL	10	254.00	12 3/8	314.33	37 1/2	952.50	15 1/2	393.70	3/4	19.05	11 1/4	285.75	9/16	14.29	333	151.1
862582100	---	10 1/8	257.18	12 1/2	317.50	38	965.20	15 5/8	396.88	3/4	19.05	11 1/4	285.75	5/8	15.88	---	---
862612100	JETTY	10 1/4	260.35	12 5/8	320.68	38 1/2	977.90	15 7/8	403.23	3/4	19.05	11 1/2	292.10	9/16	14.29	352	159.7
---	---	10 3/8	263.53	12 3/4	323.85	39	990.60	16	406.40	3/4	19.05	11 5/8	295.28	9/16	14.29	---	---
862682100	JUMBO	10 1/2	266.70	12 7/8	327.03	39 1/2	1003.30	16 1/8	409.58	3/4	19.05	11 3/4	298.45	9/16	14.29	350	158.8
---	---	10 5/8	269.88	13	330.20	40	1016.00	16 1/4	412.75	3/4	19.05	11 7/8	301.63	9/16	14.29	---	---
862742100	JUDGE	10 3/4	273.05	13 1/8	333.38	40 1/2	1028.70	16 3/8	415.93	3/4	19.05	12	304.80	9/16	14.29	368	166.9
---	---	10 7/8	276.23	13 1/4	336.55	41	1041.40	17	431.80	3/4	19.05	12 1/8	307.98	9/16	14.29	---	---
862802100	KNOCK	11	279.40	13 1/2	342.90	41 1/2	1054.10	17 1/4	438.15	3/4	19.05	12 3/8	314.33	9/16	14.29	420	190.5
---	---	11 1/8	282.58	13 5/8	346.08	42	1066.80	17 3/8	441.33	3/4	19.05	12 1/2	317.50	9/16	14.29	---	---
862872100	KRAFT	11 1/4	285.75	13 3/4	349.25	42 1/2	1079.50	17 1/2	444.50	3/4	19.05	12 5/8	320.68	9/16	14.29	432	196.0
---	---	11 3/8	288.93	14	355.60	43	1092.20	17 3/4	450.85	3/4	19.05	12 3/4	323.85	5/8	15.88	---	---
862932101	KNEEL	11 1/2	292.10	14 1/8	358.78	43 1/2	1104.90	17 7/8	454.03	3/4	19.05	12 7/8	327.03	5/8	15.88	482	218.6
862932100	KNIFE	11 1/2	292.10	14 7/8	377.83	50 3/4	1289.05	20 1/4	514.35	1 1/4	31.75	12 7/8	327.03	1	25.40	860	390.1
862962100	---	11 5/8	295.28	14 1/4	361.95	44	1117.60	18	457.20	3/4	19.05	13	330.20	5/8	15.88	---	---
862992100	KNOTS	11 3/4	298.45	14 3/8	365.13	44 1/2	1130.30	18 1/8	460.38	3/4	19.05	13 1/8	333.38	5/8	15.88	502	227.7
---	---	11 7/8	301.63	14 1/2	368.30	45	1143.00	18 1/4	463.55	3/4	19.05	13 1/4	336.55	5/8	15.88	---	---
863062100	LABOR	12	304.80	14 3/4	374.65	45 1/2	1155.70	18 1/2	469.90	3/4	19.05	13 1/2	342.90	5/8	15.88	516	234.1
863092100	LOGAN	12 1/8	307.98	14 7/8	377.83	46	1168.40	18 5/8	473.08	3/4	19.05	13 5/8	346.08	5/8	15.88	---	---
863122100	LANCE	12 1/4	311.15	15	381.00	46 1/2	1181.10	18 3/4	476.25	3/4	19.05	13 3/4	349.25	5/8	15.88	539	244.5
---	LEASE	12 3/8	314.33	15 1/8	384.18	47	1193.80	18 7/8	479.43	3/4	19.05	13 7/8	352.43	5/8	15.88	---	---
863182100	LAYER	12 1/2	317.50	15 1/4	387.35	47 1/2	1206.50	19	482.60	3/4	19.05	14	355.60	5/8	15.88	554	251.3
863222100	LOGIC	12 5/8	320.68	15 3/8	390.53	48	1219.20	19 1/8	485.78	3/4	19.05	14 1/8	358.78	5/8	15.88	582	264.0
863252100	MILKY	12 3/4	323.85	15 1/2	393.70	48 1/2	1231.90	19 1/4	488.95	3/4	19.05	14 1/4	361.95	5/8	15.88	---	---
863282100	MUSIC	12 7/8	327.03	15 5/8	396.88	49	1244.60	19 3/8	492.13	3/4	19.05	14 3/8	365.13	5/8	15.88	---	---
863312100	MINCE	13	330.20	15 7/8	403.23	50	1270.00	19 5/8	498.48	7/8	22.23	14 1/2	368.30	11/16	17.46	674	305.7
863342100	MITTY	13 1/8	333.38	16	406.40	50 1/2	1282.70	19 3/4	501.65	7/8	22.23	14 1/2	368.30	3/4	19.05	710	322.1
863372100	MISTY	13 1/4	336.55	16 1/8	409.58	51	1295.40	19 7/8	504.83	7/8	22.23	14 1/2	368.30	13/16	20.64	---	---
863412100	NIFTY	13 3/8	339.73	16 1/4	412.75	51 1/2	1308.10	19 7/8	504.83	7/8	22.23	14 1/2	368.30	7/8	22.23	696	315.7
863442100	NIECE	13 1/2	342.90	16 3/8	415.93	52	1320.80	20 1/8	511.18	7/8	22.23	15	381.00	11/16	17.46	697	316.2
863472100	NOVEL	13 5/8	346.08	16 1/2	419.10	52 1/2	1333.50	20 1/4	514.35	7/8	22.23	15 1/8	384.18	11/16	17.46	---	---
863502100	ORTHA	13 3/4	349.25	16 5/8	422.28	53	1346.20	20 3/8	517.53	7/8	22.23	15 1/4	387.35	11/16	17.46	---	---
---	OGGLE	13 7/8	352.43	16 3/4	425.45	53 1/2	1358.90	20 1/2	520.70	7/8	22.23	15 3/8	390.53	11/16	17.46	---	---
863572100	OPERA	14	355.60	16 7/8	428.63	54	1371.60	20 5/8	523.88	7/8	22.23	15 1/2	393.70	11/16	17.46	735	333.4
---	PURSE	14 1/8	358.78	17	431.80	54 1/2	1384.30	20 3/4	527.05	7/8	22.23	15 5/8	396.88	11/16	17.46	---	---
863632100	POLAR	14 1/4	361.95	17 1/8	434.98	55	1397.00	20 7/8	530.23	7/8	22.23	15 3/4	400.05	11/16	17.46	---	---
863662100	POINT	14 3/8	365.13	17 1/4	438.15	55 1/2	1409.70	21	533.40	7/8	22.23	15 7/8	403.23	11/16	17.46	842	381.9
863692100	PRUNE	14 1/2	368.30	17 1/2	444.50	56	1422.40	21 1/4	539.75	7/8	22.23	16	406.40	3/4	19.05	852	386.5
---	PRICE	14 5/8	371.48	17 5/8	447.68	56 1/2	1435.10	21 3/8	542.93	7/8	22.23	16 1/8	409.58	3/4	19.05	---	---
---	PUNCH	14 3/4	374.65	17 3/4	450.85	57	1447.80	21 1/2	546.10	7/8	22.23	16 1/4	412.75	3/4	19.05	---	---
---	QUAKE	14 7/8	377.83	17 7/8	454.03	57 1/2	1460.50	21 5/8	549.28	7/8	22.23	16 3/8	415.93	3/4	19.05	---	---
863822100	QUIET	15	381.00	18	457.20	58	1473.20	21 3/4	552.45	7/8	22.23	16 1/2	419.10	3/4	19.05	905	410.5

NOTE: Dimensions for each size bearing continue across both pages.

# Split Naval Brass Flanged Bearings

## SPLIT STRUT OR AFT STERN TUBE



FLANGE DRILLING  
DIAGRAM ON PAGE 18

Johnson Cutless® Flanged Bearings are centrifugally cast naval brass with an integral flange for bolting to stern tube or strut housing to retain bearing and prevent rotation in housing. Specially formulated oil and chemical resistant nitrile rubber is securely bonded to the shell.

Split styles offer ease of installation and change. Shells are heavy walled providing structural strength and can be step turned if desired. Flanges are furnished UN-DRILLED unless specified. See page 18 for Drilling Diagrams.

### PRECAUTION:

When shrink fitting of the bearing is required, chilling must be achieved by gradual cooling to not more than minus 20°F(-28°C) using freezer or regular ice (**DO NOT DRY ICE**). NOTE: Pounding or shocking the bearing while in the chilled state could cause the rubber to separate from the shell.

**Approved Bearings:** Johnson Cutless® Naval Brass Flanged Bearings meet military specification MIL-DTL-17901C (SH) Class II Full-Molded type and have full type approval from The American Bureau of Shipping.

Part No.	Code	A Shaft Diameter		B Outside Diameter		C Length		D Flange Diameter		E Flange Thickness		F Metal I.D.		G Metal Thickness	
		inch	mm	inch	mm	inch	mm	inch	mm	inch	mm	inch	mm	inch	mm
861532120	FAITH	6	152.40	8 1/2	215.90	20	508.00	11 5/8	295.28	5/8	15.88	7	177.80	3/4	19.05
861532121	FARCE	6	152.40	8 1/2	215.90	24	609.60	11 5/8	295.28	5/8	15.88	7	177.80	3/4	19.05
861532123	FERRY	6	152.40	8 3/4	222.25	24	609.60	11 5/8	295.28	5/8	15.88	7	177.80	7/8	22.23
—	—	6	152.40	7 7/8	200.03	21 1/2	546.10	10 3/8	263.53	9/16	14.29	7	177.80	7/16	11.11
—	—	6 1/8	155.58	8	203.20	22	558.80	10 1/2	266.70	9/16	14.29	7 1/8	180.98	7/16	11.11
—	—	6 1/4	158.75	8 1/8	206.38	22 1/2	571.50	10 5/8	269.88	9/16	14.29	7 1/4	184.15	7/16	11.11
861622120	—	6 3/8	161.93	8 1/4	209.55	23	584.20	10 3/4	273.05	9/16	14.29	7 3/8	187.33	7/16	11.11
—	—	6 1/2	165.10	8 3/8	212.73	23 1/2	596.90	11	279.40	9/16	14.29	7 1/2	190.50	7/16	11.11
—	—	6 5/8	168.28	8 5/8	219.08	24	609.60	11 1/4	285.75	9/16	14.29	7 5/8	193.68	1/2	12.70
861722120	FORCE	6 3/4	171.45	8 3/4	222.25	24	609.60	11 1/4	285.75	9/16	14.29	7 7/8	200.03	7/16	11.11
861722122	FLASH	6 3/4	171.45	8 7/8	225.43	24 1/2	622.30	11 3/8	288.93	9/16	14.29	7 7/8	200.03	1/2	12.70
—	—	7	177.80	9 1/8	231.78	25 1/2	647.70	11 5/8	295.28	9/16	14.29	8 1/8	206.38	1/2	12.70
—	—	7 1/8	180.98	9 1/4	234.95	25 1/2	647.70	11 3/4	298.45	9/16	14.29	8 1/4	209.55	1/2	12.70
—	—	7 1/4	184.15	9 3/8	238.13	26 1/2	673.10	11 7/8	301.63	9/16	14.29	8 3/8	212.73	1/2	12.70
—	—	7 3/8	187.33	9 5/8	244.48	27	685.80	12 1/8	307.98	9/16	14.29	8 5/8	219.08	1/2	12.70
861912120	GRADE	7 1/2	190.50	9 7/8	250.83	27 1/2	698.50	10 1/4	260.35	9/16	14.29	8 3/4	222.25	9/16	14.29
861912121	GRAIN	7 1/2	190.50	9 7/8	250.83	27 1/2	698.50	12 3/8	314.33	9/16	14.29	8 3/4	222.25	9/16	14.29
861912122	—	7 1/2	190.50	9 3/4	247.65	27 1/2	698.50	12 1/4	311.15	9/16	14.29	8 3/4	222.25	1/2	12.70
—	—	7 5/8	193.68	9 7/8	250.83	28	711.20	12 3/8	314.33	9/16	14.29	8 3/4	222.25	9/16	14.29
—	—	7 3/4	196.85	10	254.00	28 1/2	723.90	12 1/2	317.50	9/16	14.29	8 7/8	225.43	9/16	14.29
—	—	7 7/8	200.03	10 1/8	257.18	29	736.60	12 5/8	320.68	9/16	14.29	9 1/8	231.78	1/2	12.70
862042120	—	8	203.20	10 3/8	263.53	29 1/2	749.30	13 1/4	336.55	5/8	15.88	9 1/4	234.95	9/16	14.29
—	—	8 1/8	206.38	10 1/2	266.70	30	762.00	13 3/8	339.73	5/8	15.88	9 3/8	238.13	9/16	14.29
—	—	8 1/4	209.55	10 5/8	269.88	30 1/2	774.70	13 1/2	342.90	5/8	15.88	9 1/2	241.30	9/16	14.29
—	—	8 3/8	212.73	10 3/4	273.05	31	787.40	13 5/8	346.08	5/8	15.88	9 5/8	244.48	9/16	14.29
—	—	8 1/2	215.90	10 7/8	276.23	31 1/2	800.10	13 3/4	349.25	5/8	15.88	9 3/4	247.65	9/16	14.29
—	—	8 5/8	219.08	11	279.40	32	812.80	13 7/8	352.43	5/8	15.88	9 7/8	250.83	9/16	14.29
—	—	8 3/4	222.25	11 1/8	282.58	32 1/2	825.50	14	355.60	5/8	15.88	10	254.00	9/16	14.29
—	—	8 7/8	225.43	11 1/4	285.75	33	838.20	14 1/8	358.78	3/4	19.05	10 1/8	257.18	9/16	14.29
862292120	—	9	228.60	11 3/8	288.93	33 1/2	850.90	14 1/4	361.95	3/4	19.05	10 1/4	260.35	9/16	14.29
862332120	—	9 1/8	231.78	11 1/2	292.10	34	863.60	14 1/2	368.30	3/4	19.05	10 3/8	263.53	9/16	14.29
—	—	9 1/4	234.95	11 5/8	295.28	34 1/2	876.30	14 5/8	371.48	3/4	19.05	10 1/2	266.70	9/16	14.29
—	—	9 3/8	238.13	11 3/4	298.45	35	889.00	14 3/4	374.65	3/4	19.05	10 5/8	269.88	9/16	14.29
862422120	INSUL	9 1/2	241.30	11 7/8	301.63	20 3/4	527.05	14 3/4	374.65	1	25.40	10 3/4	273.05	9/16	14.29
862422121	—	9 1/2	241.30	11 7/8	301.63	35 1/2	901.70	14 7/8	377.83	3/4	19.05	10 3/4	273.05	9/16	14.29
—	—	9 5/8	244.48	12	304.80	36	914.40	15	381.00	3/4	19.05	10 7/8	276.23	9/16	14.29
—	—	9 3/4	247.65	12 1/4	311.15	36 1/2	927.10	15 1/4	387.35	3/4	19.05	11	279.40	5/8	15.88
—	—	9 7/8	250.83	12 3/8	314.33	37	939.80	15 3/8	390.53	3/4	19.05	11 1/8	282.58	5/8	15.88
—	—	10	254.00	12 1/2	317.50	37 1/2	952.50	15 1/2	393.70	3/4	19.05	11 1/4	285.75	11/16	17.46

NOTE: Dimensions for each size bearing continue across both pages.



- A = SHAFT DIAMETER
- B = OUTSIDE DIAMETER
- C = LENGTH
- D = FLANGE DIAMETER
- E = FLANGE THICKNESS
- F = METAL I.D.
- G = METAL THICKNESS

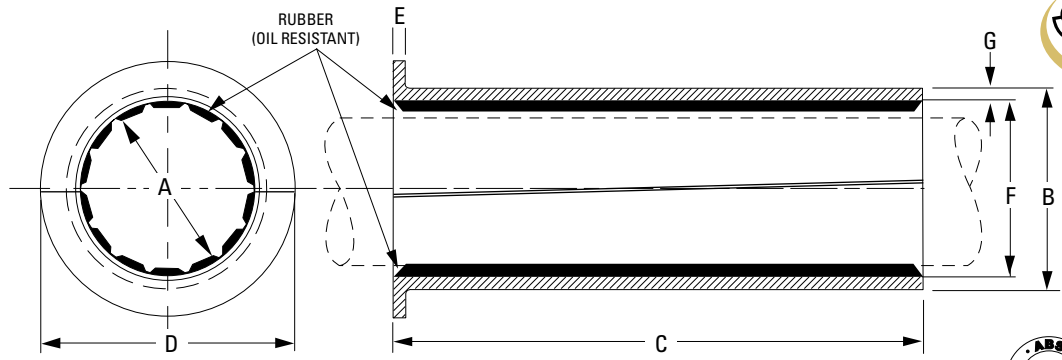

To Facilitate Assembly and Removal of Bearing — Split on Taper as Follows:  
 Split Above or Below Ctr. Line, At End: Bearing Length 1/16 ..... Up to and including 36" long



Part No.	Code	A Shaft Diameter		B Outside Diameter		C Length		D Flange Diameter		E Flange Thickness		F Metal I.D.		G Metal Thickness	
		inch	mm	inch	mm	inch	mm	inch	mm	inch	mm	inch	mm	inch	mm
862582120	—	10 1/8	257.18	12 5/8	320.68	38	965.20	15 5/8	396.88	3/4	19.05	11 1/4	285.75	5/8	15.88
864612120	—	10 1/4	260.35	12 3/4	323.85	38 1/2	977.90	15 7/8	403.23	3/4	19.05	11 1/2	292.10	5/8	15.88
—	—	10 3/8	263.53	12 7/8	327.03	39	990.60	16	406.40	3/4	19.05	11 5/8	295.28	5/8	15.88
—	—	10 1/2	266.70	13	330.20	39 1/2	1,003.30	16 1/8	409.58	3/4	19.05	11 3/4	298.45	5/8	15.88
—	—	10 5/8	269.88	13 1/8	333.38	40	1,016.00	16 1/4	412.75	3/4	19.05	11 7/8	301.63	5/8	15.88
—	—	10 3/4	273.05	13 1/4	336.55	40 1/2	1,028.70	16 3/8	415.93	3/4	19.05	12	304.80	5/8	15.88
—	—	10 7/8	276.23	13 3/8	339.73	41	1,041.40	17	431.80	3/4	19.05	12 1/8	307.98	5/8	15.88
—	—	11	279.40	13 5/8	346.08	41 1/2	1,054.10	17 1/4	438.15	3/4	19.05	12 3/8	314.33	5/8	15.88
—	—	11 1/8	282.58	13 3/4	349.25	42	1,066.80	17 3/8	441.33	3/4	19.05	12 1/2	317.50	5/8	15.88
—	—	11 1/4	285.75	13 7/8	352.43	42 1/2	1,079.50	17 1/2	444.50	3/4	19.05	12 5/8	320.68	5/8	15.88
—	—	11 3/8	288.93	14 1/8	358.78	43	1,092.20	17 3/4	450.85	3/4	19.05	12 3/4	323.85	11/16	17.46
—	—	11 1/2	292.10	14 1/4	361.95	43 1/2	1,104.90	17 7/8	454.03	3/4	19.05	12 7/8	327.03	11/16	17.46
—	—	11 5/8	295.28	14 3/8	365.13	44	1,117.60	18	457.20	3/4	19.05	13	330.20	11/16	17.46
—	—	11 3/4	298.45	14 1/2	368.30	44 1/2	1,130.30	18 1/8	460.38	3/4	19.05	13 1/8	333.38	11/16	17.46
—	—	11 7/8	301.63	14 5/8	371.48	45	1,143.00	18 1/4	463.55	3/4	19.05	13 1/4	336.55	11/16	17.46
—	—	12	304.80	14 7/8	377.83	45 1/2	1,155.70	18 1/2	469.90	3/4	19.05	13 1/2	342.90	11/16	17.46
—	—	12 1/8	307.98	15	381.00	46	1,168.40	18 5/8	473.08	3/4	19.05	13 5/8	346.08	11/16	17.46
—	—	12 1/4	311.15	15 1/8	384.18	46 1/2	1,181.10	18 3/4	476.25	3/4	19.05	13 3/4	349.25	11/16	17.46
—	—	12 3/8	314.33	15 1/4	387.35	47	1,193.80	18 7/8	479.43	3/4	19.05	13 7/8	352.43	11/16	17.46
863182120	—	12 1/2	317.50	15 3/8	390.53	47 1/2	1,206.50	19	482.60	3/4	19.05	14	355.60	11/16	17.46
—	—	12 5/8	320.68	15 1/2	393.70	48	1,219.20	19 1/8	485.78	3/4	19.05	14 1/8	358.78	11/16	17.46
—	—	12 3/4	323.85	15 5/8	396.88	48 1/2	1,231.90	19 1/4	488.95	3/4	19.05	14 1/4	361.95	11/16	17.46
—	—	12 7/8	327.03	15 3/4	400.05	49	1,244.60	19 3/8	492.13	3/4	19.05	14 3/8	365.13	11/16	17.46
832212120	—	13	330.20	16	406.40	50	1,270.00	19 5/8	498.48	7/8	22.23	14 1/2	368.30	3/4	19.05
—	—	13 1/8	333.38	16 1/8	409.58	50 1/8	1,273.18	19 3/4	501.65	7/8	22.23	14 5/8	371.48	3/4	19.05
—	—	13 1/4	336.55	16 1/4	412.75	51	1,295.40	19 7/8	504.83	7/8	22.23	14 3/4	374.65	3/4	19.05
—	—	13 3/8	339.73	16 3/8	415.93	51 1/2	1,308.10	20	508.00	7/8	22.23	14 7/8	377.83	3/4	19.05
—	—	13 1/2	342.90	16 1/2	419.10	52	1,320.80	20 1/8	511.18	7/8	22.23	15	381.00	3/4	19.05
—	—	13 5/8	346.08	16 5/8	422.28	52 1/2	1,333.50	20 1/4	514.35	7/8	22.23	15 1/8	384.18	3/4	19.05
—	—	13 3/4	349.25	16 3/4	425.45	53	1,346.20	20 3/8	517.53	7/8	22.23	15 1/4	387.35	3/4	19.05
—	—	13 7/8	352.43	16 7/8	428.63	53 1/2	1,358.90	20 1/2	520.70	7/8	22.23	15 3/8	390.53	3/4	19.05
—	—	14	355.60	17	431.80	54	1,371.60	20 5/8	523.88	7/8	22.23	15 1/2	393.70	3/4	19.05
—	—	14 1/8	358.78	17 1/8	434.98	54 1/2	1,384.30	20 3/4	527.05	7/8	22.23	15 5/8	396.88	3/4	19.05
—	—	14 1/4	361.95	17 1/4	438.15	55	1,397.00	20 7/8	530.23	7/8	22.23	15 3/4	400.05	3/4	19.05
—	—	14 3/8	365.13	17 3/8	441.33	55 1/2	1,409.70	21	533.40	7/8	22.23	15 7/8	403.23	3/4	19.05
—	—	14 1/2	368.30	17 5/8	447.68	56	1,422.40	21 1/4	539.75	7/8	22.23	16	406.40	13/16	20.64
—	—	14 5/8	371.48	17 3/4	450.85	56 1/2	1,435.10	21 3/8	542.93	7/8	22.23	16 1/8	409.58	13/16	20.64
—	—	14 3/4	374.65	17 7/8	454.03	57	1,447.80	21 1/2	546.10	7/8	22.23	16 1/4	412.75	13/16	20.64
—	—	14 7/8	377.83	18	457.20	57 1/2	1,460.50	21 5/8	549.28	7/8	22.23	16 3/8	415.93	13/16	20.64
—	—	15	381.00	18 1/8	460.38	58	1,473.20	21 3/4	552.45	7/8	22.23	16 1/2	419.10	13/16	20.64

NAVAL BRASS FLANGED

# Solid Naval Brass Flanged Bearings

## FORWARD STERN TUBE

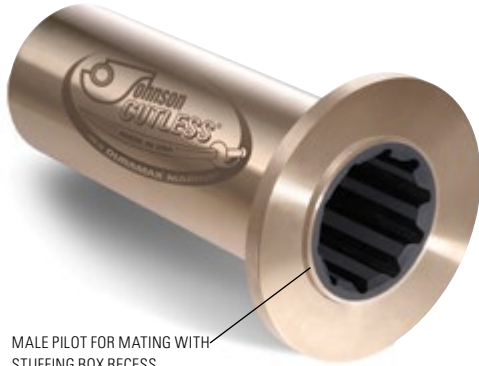

MALE PILOT FOR MATING WITH STUFFING BOX RECESS

Johnson Cutless Forward Stern Tube Flanged Bearings are made of centrifugally cast naval brass and feature a heavy metal wall and integral flange. The specially formulated nitrile rubber compound is securely bonded to metal shell and is chemical and oil resistant. The integral flange permits solid bolting of the bearing to stern tube stuffing box. The machined male pilot on the integral flange mates with the female recess of the stuffing box. Flanges are furnished UN-DRILLED unless specified. See page 18 for "Drilling Diagrams". For Split or Stepped styles see pages 14-17.

### PRECAUTION:

When shrink fitting of the bearing is required, chilling must be achieved by gradual cooling to not more than minus 20°F (-28°C) using freezer or regular ice (**DO NOT DRY ICE**). NOTE: Pounding or shocking the bearing while in the chilled state could cause the rubber to separate from the shell.

**Approved Bearings:** Johnson Cutless® Naval Brass Flanged Bearings meet military specification MIL-DTL-17901C (SH) Class II Full-Molded type and have full type approval from The American Bureau of Shipping.

Part No.	Code	A Shaft Diameter		B Outside Diameter		C Length		D Flange Diameter		E Flange Thickness		F Metal I.D.		G Metal Thickness		M Pilot Diameter		N Pilot Thickness		Gross Wt.	
		inch	mm	inch	mm	inch	mm	inch	mm	inch	mm	inch	mm	inch	mm	inch	mm	inch	mm	lbs.	kg.
860642180	212	2 1/2	63.50	3 3/8	85.73	10	254.00	6 1/4	158.75	3/8	9.53	3 1/8	79.38	1/8	3.18	4	101.60	3/16	4.76	12	5.4
860762180	300	3	76.20	4 1/4	107.95	12	304.80	7 1/2	190.50	1/2	12.70	3 3/4	95.25	1/4	6.35	4 3/4	120.65	3/16	4.76	21	9.5
860832180	314	3 1/4	82.55	4 1/2	114.30	13	330.20	7 1/2	190.50	1/2	12.70	4	101.60	1/4	6.35	4 3/4	120.65	3/16	4.76	24	10.9
860892180	312	3 1/2	88.90	4 7/8	123.83	14	355.60	8 1/8	206.38	1/2	12.70	4 1/4	107.95	5/16	7.94	5 1/4	133.35	3/16	4.76	38	17.2
860952180	334	3 3/4	95.25	5 1/4	133.35	15	381.00	8 1/8	206.38	1/2	12.70	4 5/8	117.48	5/16	7.94	5 1/4	133.35	3/16	4.76	43	19.5
861022180	400	4	101.60	5 1/2	139.70	16	406.40	8 5/8	219.08	1/2	12.70	4 7/8	123.83	5/16	7.94	5 3/4	146.05	3/16	4.76	48	21.8
861082180	414	4 1/4	107.95	5 3/4	146.05	17	431.80	8 5/8	219.08	1/2	12.70	5 1/8	130.18	5/16	7.94	5 3/4	146.05	3/16	4.76	52	23.6
861152180	412	4 1/2	114.30	6	152.40	18	457.20	9 3/8	238.13	1/2	12.70	5 3/8	136.53	5/16	7.94	6 1/2	165.10	3/16	4.76	58	26.3
861212180	434	4 3/4	120.65	6 1/4	158.75	19	482.60	9 3/8	238.13	1/2	12.70	5 5/8	142.88	5/16	7.94	6 1/2	165.10	3/16	4.76	61	27.7
861272180	500	5	127.00	6 3/4	171.45	20	508.00	10 1/8	257.18	9/16	14.29	6	152.40	3/8	9.53	7 1/4	184.15	3/16	4.76	75	34.0
861342181	514	5 1/4	133.35	6 7/8	174.63	21	533.40	10 1/8	257.18	9/16	14.29	6 1/8	155.58	3/8	9.53	7 1/4	184.15	3/16	4.76	79	35.8
861402180	512	5 1/2	139.70	7 1/4	184.15	22	558.80	10 5/8	269.88	9/16	14.29	6 1/2	165.10	3/8	9.53	7 3/4	196.85	3/16	4.76	90	40.8
861462180	534	5 3/4	146.05	7 1/4	184.15	23	584.20	10 5/8	269.88	9/16	14.29	6 1/2	165.10	3/8	9.53	7 3/4	196.85	3/16	4.76	92	41.7
861532180	600	6	152.40	7 3/4	196.85	15	381.00	11 3/8	288.93	9/16	14.29	7	177.80	3/8	9.53	8	203.20	3/8	9.53	75	34.0
—	618	6 1/8	155.58	7 7/8	200.03	15	381.00	12 1/4	311.15	9/16	14.29	7 1/8	180.98	3/8	9.53	8	203.20	3/8	9.53	-	-
861592180	614	6 1/4	158.75	7 7/8	200.03	15	381.00	11 3/8	288.93	9/16	14.29	7 1/8	180.98	3/8	9.53	8	203.20	3/8	9.53	77	34.9
—	638	6 3/8	161.93	8 1/8	206.38	15	381.00	12 5/8	320.68	9/16	14.29	7 3/8	187.33	3/8	9.53	8 3/8	212.73	3/8	9.53	-	-
861662180	612	6 1/2	165.10	8 3/8	212.73	15	381.00	13 1/2	342.90	5/8	15.88	7 1/2	190.50	7/16	11.11	8 5/8	219.08	3/8	9.53	91	41.3
861692180	FETCH	6 5/8	168.28	8 5/8	219.08	15	381.00	13 1/2	342.90	5/8	15.88	7 5/8	193.68	1/2	12.70	8 5/8	219.08	3/8	9.53	104	47.2
—	658	6 5/8	168.28	8 1/2	215.90	15	381.00	13 1/2	342.90	5/8	15.88	7 5/8	193.68	7/16	11.11	8 5/8	219.08	3/8	9.53	-	-
861722180	634	6 3/4	171.45	8 3/4	222.25	15	381.00	13 3/4	349.25	5/8	15.88	7 7/8	200.03	7/16	11.11	9	228.60	3/8	9.53	99	44.9
—	678	6 7/8	174.63	8 7/8	225.43	15	381.00	13 3/4	349.25	5/8	15.88	8	203.20	7/16	11.11	9	228.60	3/8	9.53	-	-
861782180	700	7	177.80	9	228.60	17 1/2	444.50	13 3/4	349.25	5/8	15.88	8 1/8	206.38	7/16	11.11	9	228.60	3/8	9.53	116	52.6
—	718	7 1/8	180.98	9 1/8	231.78	17 1/2	444.50	14 1/8	358.78	5/8	15.88	8 1/4	209.55	7/16	11.11	9 5/8	244.48	3/8	9.53	-	-
861852180	714	7 1/4	184.15	9 1/4	234.95	17 1/2	444.50	14 1/8	358.78	5/8	15.88	8 3/8	212.73	7/16	11.11	9 5/8	244.48	3/8	9.53	122	55.3
—	738	7 3/8	187.33	9 1/2	241.30	17 1/2	444.50	14 1/8	358.78	5/8	15.88	8 5/8	219.08	7/16	11.11	9 5/8	244.48	3/8	9.53	-	-
861912180	712	7 1/2	190.50	9 5/8	244.48	17 1/2	444.50	14 1/2	368.30	5/8	15.88	8 3/4	222.25	7/16	11.11	10	254.00	3/8	9.53	123	55.8
—	758	7 5/8	193.68	9 3/4	247.65	17 1/2	444.50	14 1/2	368.30	5/8	15.88	8 7/8	225.43	7/16	11.11	10	254.00	3/8	9.53	-	-
861972180	734	7 3/4	196.85	9 7/8	250.83	17 1/2	444.50	14 1/2	368.30	5/8	15.88	8 7/8	225.43	1/2	12.70	10	254.00	3/8	9.53	126	57.2
—	778	7 7/8	200.03	10	254.00	17 1/2	444.50	14 7/8	377.76	5/8	15.88	9 1/8	231.78	7/16	11.11	10 3/8	263.53	3/8	9.53	-	-
862042180	HARDY	8	203.20	10 1/4	260.35	20	508.00	14 7/8	377.76	5/8	15.88	9 1/4	234.95	1/2	12.70	10 3/8	263.53	3/8	9.53	145	65.8
—	818	8 1/8	206.38	10 3/8	263.53	20	508.00	14 7/8	377.76	5/8	15.88	9 3/8	238.13	1/2	12.70	10 3/8	263.53	3/8	9.53	-	-
862102180	814	8 1/4	209.55	10 1/2	266.70	20	508.00	15 1/4	387.35	5/8	15.88	9 1/2	241.30	1/2	12.70	10 3/4	273.05	3/8	9.53	157	71.2
—	838	8 3/8	212.73	10 5/8	269.88	20	508.00	15 1/4	387.35	5/8	15.88	9 5/8	244.48	1/2	12.70	10 3/4	273.05	3/8	9.53	162	73.5
862172180	812	8 1/2	215.90	10 3/4	273.05	20	508.00	15 1/4	387.35	5/8	15.88	9 3/4	247.65	1/2	12.70	10 3/4	273.05	3/8	9.53	162	73.5
—	858	8 5/8	219.08	10 7/8	276.23	20	508.00	15 5/8	396.88	3/4	19.05	9 7/8	250.83	1/2	12.70	11 1/8	282.58	3/8	9.53	-	-
862232180	834	8 3/4	222.25	11	279.40	20	508.00	15 5/8	396.88	3/4	19.05	10	254.00	1/2	12.70	11 1/8	282.58	3/8	9.53	170	77.1
—	878	8 7/8	225.43	11 1/8	282.58	20	508.00	15 5/8	396.88	3/4	19.05	10 1/8	257.18	1/2	12.70	11 1/8	282.58	3/8	9.53	-	-
862292180	900	9	228.60	11 1/4	285.75	22 1/2	571.50	16	406.40	3/4	19.05	10 1/4	260.35	1/2	12.70	11 1/2	292.10	3/8	9.53	193	87.5
—	918	9 1/8	231.78	11 3/8	288.93	22 1/2	571.50	16	406.40	3/4	19.05	10 3/8	263.53	1/2	12.70	11 1/2	292.10	3/8	9.53	-	-
862362180	INLET	9 1/4	234.95	11 1/2	292.10	22 1/2	571.50	16	406.40	3/4	19.05	10 1/2	266.70	1/2	12.70	11 1/2	292.10	3/8	9.53	200	90.7
—	938	9 3/8	238.13	11 5/8	295.28	22 1/2	571.50	16 3/8	415.93	3/4	19.05	10 5/8	269.88	1/2	12.70	11 7/8	301.63	3/8	9.53	-	-
862422180	912	9 1/2	241.30	11 3/4	298.45	22 1/2	571.50	16 3/8	415.93	3/4	19.05	10 3/4	273.05	1/2	12.70	11 7/8	301.63	3/8	9.53	205	93.0

NOTE: Dimensions for each size bearing continue across both pages.

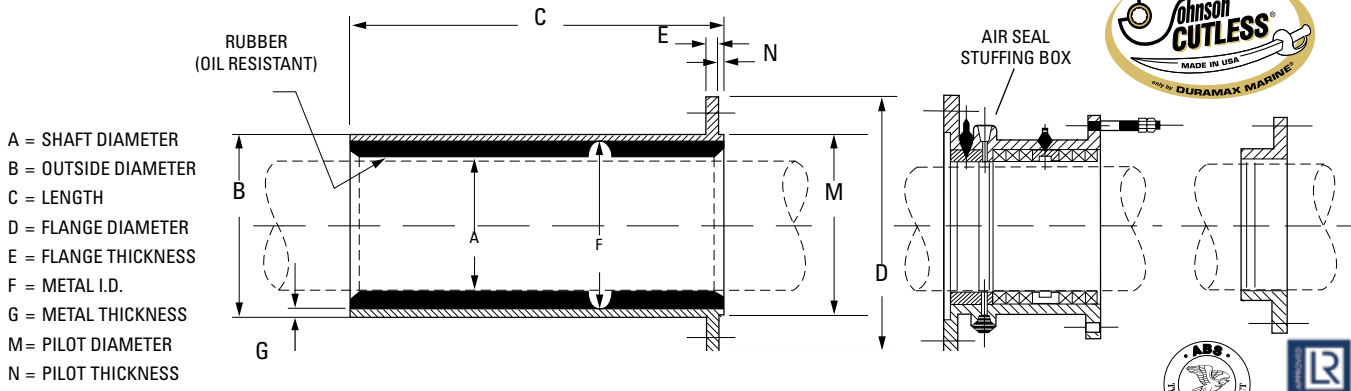

- A = SHAFT DIAMETER
- B = OUTSIDE DIAMETER
- C = LENGTH
- D = FLANGE DIAMETER
- E = FLANGE THICKNESS
- F = METAL I.D.
- G = METAL THICKNESS
- M = PILOT DIAMETER
- N = PILOT THICKNESS

Part No.	Code	A Shaft Diameter		B Outside Diameter		C Length		D Flange Diameter		E Flange Thickness		F Metal I.D.		G Metal Thickness		M Pilot Diameter		N Pilot Thickness		Gross Wt.	
		inch	mm	inch	mm	inch	mm	inch	mm	inch	mm	inch	mm	inch	mm	inch	mm	inch	mm	lbs.	kg.
862452182	958	9 5/8	244.48	11 7/8	301.63	22 1/2	571.50	16 3/8	415.93	3/4	19.05	10 7/8	276.23	1/2	12.70	11 7/8	301.63	3/8	9.53	-	-
862482180	934	9 3/4	247.65	12 1/8	307.98	22 1/2	571.50	16 7/8	428.56	3/4	19.05	11	279.40	9/16	14.29	12 3/8	314.33	3/8	9.53	217	98.4
862522180	978	9 7/8	250.83	12 1/4	311.15	22 1/2	571.50	16 7/8	428.56	3/4	19.05	11 1/8	282.58	9/16	14.29	12 3/8	314.33	3/8	9.53	-	-
862552180	1000	10	254.00	12 3/8	314.33	25	635.00	16 7/8	428.56	3/4	19.05	11 1/4	285.75	9/16	14.29	12 3/8	314.33	3/8	9.53	240	108.9
—	1018	10 1/8	257.18	12 1/2	317.50	25	635.00	17 7/8	453.96	3/4	19.05	11 3/8	288.93	9/16	14.29	12 3/4	323.85	3/8	9.53	-	-
862612180	1014	10 1/4	260.35	12 5/8	320.68	25	635.00	17 7/8	453.96	3/4	19.05	11 1/2	292.10	9/16	14.29	12 3/4	323.85	3/8	9.53	244	110.7
—	1038	10 3/8	263.53	12 3/4	323.85	25	635.00	17 7/8	453.96	3/4	19.05	11 5/8	295.28	9/16	14.29	12 3/4	323.85	3/8	9.53	-	-
862682180	1012	10 1/2	266.70	12 7/8	327.03	25	635.00	18 1/4	463.55	3/4	19.05	11 3/4	298.45	9/16	14.29	13 1/8	333.38	3/8	9.53	247	112.0
—	1058	10 5/8	269.88	13	330.20	25	635.00	18 1/4	463.55	3/4	19.05	11 7/8	301.63	9/16	14.29	13 1/8	333.38	3/8	9.53	-	-
862742180	JOLLY	10 3/4	273.05	13 1/8	333.38	25	635.00	18 1/4	463.55	3/4	19.05	12	304.80	9/16	14.29	13 1/8	333.38	3/8	9.53	250	113.4
—	1078	10 7/8	276.23	13 1/4	336.55	25	635.00	18 5/8	473.08	3/4	19.05	12 1/8	307.98	9/16	14.29	13 1/2	342.90	3/8	9.53	-	-
862802180	KETCH	11	279.40	13 1/2	342.90	27 1/2	698.50	18 5/8	473.08	3/4	19.05	12 3/8	314.33	9/16	14.29	13 1/2	342.90	3/8	9.53	300	136.1
—	1118	11 1/8	282.58	13 5/8	346.08	27 1/2	698.50	18 5/8	473.08	3/4	19.05	12 1/2	317.50	9/16	14.29	13 1/2	342.90	3/8	9.53	-	-
862872180	1114	11 1/4	285.75	13 3/4	349.25	27 1/2	698.50	19	482.60	3/4	19.05	12 5/8	320.68	9/16	14.29	13 7/8	352.43	3/8	9.53	312	141.5
—	1138	11 3/8	288.93	14	355.60	27 1/2	698.50	19	482.60	3/4	19.05	12 3/4	323.85	5/8	15.88	13 7/8	352.43	3/8	9.53	-	-
862932180	1112	11 1/2	292.10	14 1/8	358.78	27 1/2	698.50	19	482.60	3/4	19.05	12 7/8	327.03	5/8	15.88	13 7/8	352.43	3/8	9.53	326	147.9
—	1158	11 5/8	295.28	14 1/4	361.95	27 1/2	698.50	19 3/8	492.13	3/4	19.05	13	330.20	5/8	15.88	14 1/8	358.78	3/8	9.53	-	-
862992180	1134	11 3/4	298.45	14 3/8	365.13	27 1/2	698.50	19 3/8	492.13	3/4	19.05	13 1/8	333.38	5/8	15.88	14 1/8	358.78	3/8	9.53	335	152.0
—	1178	11 7/8	301.63	14 1/2	368.30	27 1/2	698.50	19 3/8	492.13	3/4	19.05	13 1/4	336.55	5/8	15.88	14 1/8	358.78	3/8	9.53	-	-
863062180	1200	12	304.80	14 3/4	374.65	30	762.00	19 3/4	501.65	3/4	19.05	13 1/2	342.90	5/8	15.88	14 1/2	368.30	3/8	9.53	360	163.3
863092180	1218	12 1/8	307.98	14 7/8	377.83	30	762.00	19 3/4	501.65	3/4	19.05	13 5/8	346.08	5/8	15.88	14 1/2	368.30	3/8	9.53	-	-
863122180	1214	12 1/4	311.15	15	381.00	30	762.00	19 3/4	501.65	3/4	19.05	13 3/4	349.25	5/8	15.88	14 1/2	368.30	3/8	9.53	373	169.2
863152180	1238	12 3/8	314.33	15 1/8	384.18	30	762.00	20 1/8	511.18	7/8	22.23	13 7/8	352.43	5/8	15.88	15 1/8	384.18	3/8	9.53	-	-
863182180	1212	12 1/2	317.50	15 1/4	387.35	30	762.00	20 1/8	511.18	7/8	22.23	14	355.60	5/8	15.88	15 1/8	384.18	3/8	9.53	394	178.7
863222180	1258	12 5/8	320.68	15 3/8	390.53	30	762.00	20 1/8	511.18	7/8	22.23	14 1/8	358.78	5/8	15.88	15 1/8	384.18	3/8	9.53	-	-
—	1234	12 3/4	323.85	15 1/2	393.70	30	762.00	20 1/2	520.70	7/8	22.23	14 1/4	361.95	5/8	15.88	15 1/2	393.70	3/8	9.53	-	-
—	1278	12 7/8	327.03	15 5/8	396.88	30	762.00	20 1/2	520.70	7/8	22.23	14 3/8	365.13	5/8	15.88	15 1/2	393.70	3/8	9.53	-	-
—	1300	13	330.20	15 7/8	403.23	32 1/2	825.50	20 1/2	520.70	7/8	22.23	14 1/2	368.30	11/16	17.46	15 1/2	393.70	3/8	9.53	-	-
—	1318	13 1/8	333.38	16	406.40	32 1/2	825.50	21	533.40	7/8	22.23	14 5/8	371.48	11/16	17.46	15 3/4	400.05	3/8	9.53	-	-
—	1314	13 1/4	336.55	16 1/8	409.58	32 1/2	825.50	21	533.40	7/8	22.23	14 3/4	374.65	11/16	17.46	15 3/4	400.05	3/8	9.53	-	-
—	1338	13 3/8	339.73	16 1/4	412.75	32 1/2	825.50	21	533.40	7/8	22.23	14 7/8	377.83	11/16	17.46	15 3/4	400.05	3/8	9.53	-	-
863442181	1312	13 1/2	342.90	16 3/8	415.93	32 1/2	825.50	21 3/8	542.93	7/8	22.23	15	381.00	11/16	17.46	16 1/4	412.75	3/8	9.53	-	-
863472180	1358	13 5/8	346.08	16 1/2	419.10	32 1/2	825.50	21 3/8	542.93	7/8	22.23	15 1/8	384.18	11/16	17.46	16 1/4	412.75	3/8	9.53	-	-
—	1334	13 3/4	349.25	16 5/8	422.28	32 1/2	825.50	21 3/8	542.93	7/8	22.23	15 1/4	387.35	11/16	17.46	16 1/4	412.75	3/8	9.53	-	-
—	1378	13 7/8	352.43	16 3/4	425.45	32 1/2	825.50	21 3/4	552.45	7/8	22.23	15 3/8	390.53	11/16	17.46	16 5/8	422.28	3/8	9.53	-	-
—	1400	14	355.60	16 7/8	428.63	35	889.00	21 3/4	552.45	7/8	22.23	15 1/2	393.70	11/16	17.46	16 5/8	422.28	3/8	9.53	-	-
—	1418	14 1/8	358.78	17	431.80	35	889.00	21 3/4	552.45	7/8	22.23	15 5/8	396.88	11/16	17.46	16 5/8	422.28	3/8	9.53	-	-
—	1414	14 1/4	361.95	17 1/8	434.98	35	889.00	22 1/8	561.98	7/8	22.23	15 3/4	400.05	11/16	17.46	17 1/4	438.15	3/8	9.53	-	-
—	1438	14 3/8	365.13	17 1/4	438.15	35	889.00	22 1/8	561.98	7/8	22.23	15 7/8	403.23	11/16	17.46	17 1/4	438.15	3/8	9.53	-	-
—	1412	14 1/2	368.30	17 1/2	444.50	35	889.00	22 1/8	561.98	7/8	22.23	16	406.40	3/4	19.05	17 1/4	438.15	3/8	9.53	-	-
—	1458	14 5/8	371.48	17 5/8	447.68	35	889.00	22 1/2	571.50	7/8	22.23	16 1/8	409.58	3/4	19.05	17 1/2	444.50	3/8	9.53	-	-
—	1434	14 3/4	374.65	17 3/4	450.85	35	889.00	22 1/2	571.50	7/8	22.23	16 1/4	412.75	3/4	19.05	17 1/2	444.50	3/8	9.53	-	-
—	1478	14 7/8	377.83	17 7/8	454.03	35	889.00	22 3/4	577.85	7/8	22.23	16 3/8	415.93	3/4	19.05	17 3/4	450.85	3/8	9.53	-	-
—	1500	15	381.00	18	457.20	35	889.00	22 3/4	577.85	7/8	22.23	16 1/2	419.10	3/4	19.05	17 3/4	450.85	3/8	9.53	-	-

NOTE: Dimensions for each size bearing continue across both pages.

NAVAL BRASS FLANGED

# Split Naval Brass Flanged Bearings

## SPLIT FORWARD STERN TUBE

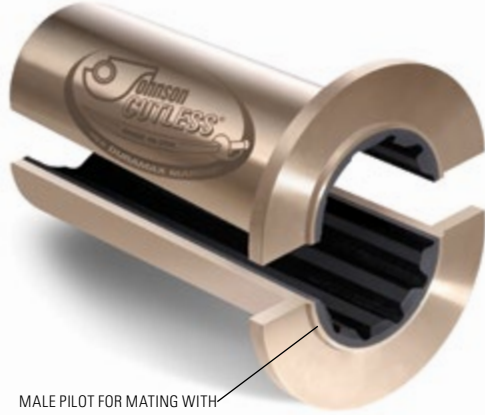

MALE PILOT FOR MATING WITH STUFFING BOX RECESS

Made of the same engineered quality as other Johnson Cutless® Naval Brass Bearings, these Flanged Bearings for Forward Stern Tube installation have a male pilot designed to mate with the female recess in the Stuffing Box flange. Stuffing Box has an inlet for piping water to lubricate bearings.

Split styles offer ease of installation and change. Sufficient space is required to move stuffing box forward to enable withdrawal of Forward Stern Tube Bearing. Space allocated should be equal to the combined length of both the Forward Stern Tube Bearing and Stuffing Box, plus two inches. Consult factory when dimensions are less than dimensions specified.

### APPROVED BEARINGS:

Johnson Cutless® Naval Brass Flanged Bearings meet military specification MIL-DTL-17901C (Ships) Class II Full-Molded type. Flanged are furnished NOT DRILLED unless specified. See page 18 for "Drilling Diagrams". NOTE: for Johnson Stuffing Box Dimensional Data, contact Duramax Marine® LLC.

### PRECAUTION:

When shrink fitting of the bearing is required, chilling must be achieved by gradual cooling to not more than minus 20°F (-28°C) using freezer or regular ice (**DO NOT DRY ICE**). NOTE: Pounding or shocking the bearing while in the chilled state could cause the rubber to separate from the shell.

**Approved Bearings:** Johnson Cutless® Naval Brass Flanged Bearings meet military specification MIL-DTL-17901C (SH) Class II Full-Molded type and have full type approval from The American Bureau of Shipping.

Part No.	Code	A Shaft Diameter		B Outside Diameter		C Length		D Flange Diameter		E Flange Thickness		F Metal I.D.		G Metal Thickness		M Pilot Diameter		N Pilot Thickness		Gross Wt.	
		inch	mm	inch	mm	inch	mm	inch	mm	inch	mm	inch	mm	inch	mm	inch	mm	inch	mm	lbs.	kg.
861532190	FLAKE	6	152.40	8 3/4	222.25	20	508.00	11 5/8	295.28	5/8	15.88	7	177.80	7/8	22.23	8	203.20	1/4	6.35	-	-
-	600	6	152.40	7 7/8	200.03	15	381.00	12 1/4	311.15	9/16	14.29	7	177.80	7/16	11.11	8	203.20	3/8	9.53	-	-
-	618	6 1/8	155.58	8	203.20	15	381.00	12 1/4	311.15	9/16	14.29	7 1/8	180.98	7/16	11.11	8	203.20	3/8	9.53	-	-
-	614	6 1/4	158.75	8 1/8	206.38	15	381.00	12 5/8	320.68	9/16	14.29	7 1/4	184.15	7/16	11.11	8 3/8	212.73	3/8	9.53	-	-
861622190	638	6 3/8	161.93	8 1/4	209.55	15	381.00	12 5/8	320.68	9/16	14.29	7 3/8	187.33	7/16	11.11	8 3/8	212.73	3/8	9.53	-	-
861662190	612	6 1/2	165.10	8 3/8	212.73	15	381.00	13 1/2	342.90	5/8	15.88	7 1/2	190.50	7/16	11.11	8 5/8	219.08	3/8	9.53	-	-
-	658	6 5/8	168.28	8 5/8	219.08	15	381.00	13 1/2	342.90	5/8	15.88	7 5/8	193.68	1/2	12.70	8 5/8	219.08	3/8	9.53	-	-
861722190	634	6 3/4	171.45	8 7/8	225.43	15	381.00	13 3/4	349.25	5/8	15.88	7 7/8	200.03	1/2	12.70	9	228.60	3/8	9.53	-	-
-	678	6 7/8	174.63	9	228.60	15	381.00	13 3/4	349.25	5/8	15.88	8	203.20	1/2	12.70	9	228.60	3/8	9.53	-	-
-	700	7	177.80	9 1/8	231.78	17 1/2	444.50	13 3/4	349.25	5/8	15.88	8 1/8	206.38	1/2	12.70	9	228.60	3/8	9.53	-	-
-	718	7 1/8	180.98	9 1/4	234.95	17 1/2	444.50	14 1/8	358.78	5/8	15.88	8 1/4	209.55	1/2	12.70	9 5/8	244.48	3/8	9.53	-	-
-	714	7 1/4	184.15	9 3/8	238.13	17 1/2	444.50	14 1/8	358.78	5/8	15.88	8 3/8	212.73	1/2	12.70	9 5/8	244.48	3/8	9.53	-	-
-	738	7 3/8	187.33	9 5/8	244.48	17 1/2	444.50	14 1/8	358.78	5/8	15.88	8 5/8	219.08	1/2	12.70	9 5/8	244.48	3/8	9.53	-	-
861912190	712	7 1/2	190.50	9 3/4	247.65	17 1/2	444.50	14 1/2	368.30	5/8	15.88	8 3/4	222.25	1/2	12.70	10	254.00	3/8	9.53	-	-
-	758	7 5/8	193.68	9 7/8	250.83	17 1/2	444.50	14 1/2	368.30	5/8	15.88	8 7/8	225.43	1/2	12.70	10	254.00	3/8	9.53	-	-
-	734	7 3/4	196.85	10	254.00	17 1/2	444.50	14 1/2	368.30	5/8	15.88	9	228.60	1/2	12.70	10	254.00	3/8	9.53	-	-
-	778	7 7/8	200.03	10 1/8	257.18	17 1/2	444.50	14 7/8	377.83	5/8	15.88	9 1/8	231.78	1/2	12.70	10 3/8	263.53	3/8	9.53	-	-
-	800	8	203.20	10 3/8	263.53	20	508.00	14 7/8	377.83	5/8	15.88	9 1/4	234.95	9/16	14.29	10 3/8	263.53	3/8	9.53	-	-
-	818	8 1/8	206.38	10 1/2	266.70	20	508.00	14 7/8	377.83	5/8	15.88	9 3/8	238.13	9/16	14.29	10 3/8	263.53	3/8	9.53	-	-
-	814	8 1/4	209.55	10 5/8	269.88	20	508.00	15 1/4	387.35	5/8	15.88	9 1/2	241.30	9/16	14.29	10 3/4	273.05	3/8	9.53	-	-
-	838	8 3/8	212.73	10 3/4	273.05	20	508.00	15 1/4	387.35	5/8	15.88	9 5/8	244.48	9/16	14.29	10 3/4	273.05	3/8	9.53	-	-
-	812	8 1/2	215.90	10 7/8	276.23	20	508.00	15 1/4	387.35	5/8	15.88	9 3/4	247.65	9/16	14.29	10 3/4	273.05	3/8	9.53	-	-
862202190	858	8 5/8	219.08	11	279.40	20	508.00	15 5/8	396.88	3/4	19.05	9 7/8	250.83	9/16	14.29	11 1/8	282.58	3/8	9.53	-	-
-	834	8 3/4	222.25	11 1/8	282.58	20	508.00	15 5/8	396.88	3/4	19.05	10	254.00	9/16	14.29	11 1/8	282.58	3/8	9.53	-	-
862262190	878	8 7/8	225.43	11 1/4	285.75	20	508.00	15 5/8	396.88	3/4	19.05	10 1/8	257.18	9/16	14.29	11 1/8	282.58	3/8	9.53	-	-
-	900	9	228.60	11 3/8	288.93	22 1/2	571.50	16	406.40	3/4	19.05	10 1/4	260.35	9/16	14.29	11 1/2	292.10	3/8	9.53	-	-
-	918	9 1/8	231.78	11 1/2	292.10	22 1/2	571.50	16	406.40	3/4	19.05	10 3/8	263.53	9/16	14.29	11 1/2	292.10	3/8	9.53	-	-
-	914	9 1/4	234.95	11 5/8	295.28	22 1/2	571.50	16	406.40	3/4	19.05	10 1/2	266.70	9/16	14.29	11 1/2	292.10	3/8	9.53	-	-
-	938	9 3/8	238.13	11 3/4	298.45	22 1/2	571.50	16 3/8	415.93	3/4	19.05	10 5/8	369.88	9/16	14.29	11 7/8	301.63	3/8	9.53	-	-
-	912	9 1/2	241.30	11 3/4	298.45	22 1/2	571.50	16 3/8	415.93	3/4	19.05	10 3/4	273.05	9/16	14.29	11 7/8	301.63	3/8	9.53	-	-
-	958	9 5/8	244.48	12	304.80	22 1/2	571.50	16 3/8	415.93	3/4	19.05	10 7/8	276.23	9/16	14.29	11 7/8	301.63	3/8	9.53	-	-
-	934	9 3/4	247.65	12 1/4	311.15	22 1/2	571.50	16 7/8	428.63	3/4	19.05	11	279.40	5/8	15.88	12 3/8	314.33	3/8	9.53	-	-
-	978	9 7/8	250.83	12 3/8	314.33	22 1/2	571.50	16 7/8	428.63	3/4	19.05	11 1/8	282.58	5/8	15.88	12 3/8	314.33	3/8	9.53	-	-
-	1000	10	254.00	12 1/2	317.50	25	635.00	16 7/8	428.63	3/4	19.05	11 1/4	285.75	5/8	15.88	12 3/8	314.33	3/8	9.53	-	-
-	1018	10 1/8	257.18	12 5/8	320.68	25	635.00	17 7/8	454.03	3/4	19.05	11 3/8	288.93	5/8	15.88	12 3/4	323.85	3/8	9.53	-	-
-	1014	10 1/4	260.35	12 3/4	323.85	25	635.00	17 7/8	454.03	3/4	19.05	11 1/2	292.10	5/8	15.88	12 3/4	323.85	3/8	9.53	-	-
-	1038	10 3/8	263.53	12 7/8	327.03	25	635.00	17 7/8	454.03	3/4	19.05	11 5/8	295.28	5/8	15.88	12 3/4	323.85	3/8	9.53	-	-

NOTE: Dimensions for each size bearing continue across both pages.



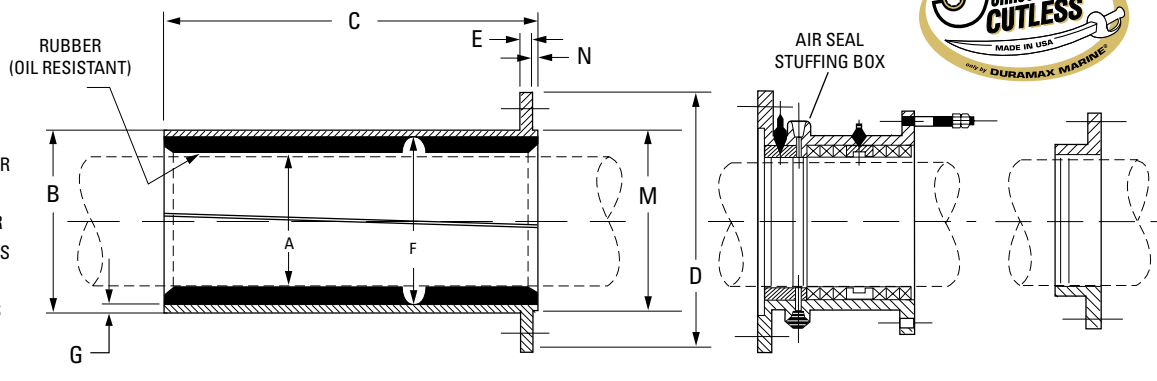

To Facilitate Assembly and Removal of Bearing — Split on Taper as Follows:  
 Split Above or Below Ctr. Line, At End: Bearing Length 1/16 ..... Up to and including 36" long



Part No.	Code	A Shaft Diameter		B Outside Diameter		C Length		D Flange Diameter		E Flange Thickness		F Metal I.D.		G Metal Thickness		M Pilot Diameter		N Pilot Thickness		Gross Wt.	
		inch	mm	inch	mm	inch	mm	inch	mm	inch	mm	inch	mm	inch	mm	inch	mm	inch	mm	lbs.	kg.
-	1012	10 1/2	266.70	13	330.20	25	635.00	18 1/4	463.55	3/4	19.05	11 3/4	298.45	5/8	15.88	13 1/8	333.38	3/8	9.53	-	-
-	1058	10 5/8	269.88	13 1/8	333.38	25	635.00	18 1/4	463.55	3/4	19.05	11 7/8	301.63	5/8	15.88	13 1/8	333.38	3/8	9.53	-	-
-	1034	10 3/4	273.05	13 1/4	336.55	25	635.00	18 1/4	463.55	3/4	19.05	12	304.80	5/8	15.88	13 1/8	333.38	3/8	9.53	-	-
-	1078	10 7/8	276.23	13 3/8	339.73	25	635.00	18 5/8	473.08	3/4	19.05	12 1/8	307.98	5/8	15.88	13 1/2	342.90	3/8	9.53	-	-
-	1100	11	279.40	13 5/8	346.08	27 1/2	698.50	18 5/8	473.08	3/4	19.05	12 3/8	314.33	5/8	15.88	13 1/2	342.90	3/8	9.53	-	-
-	1118	11 1/8	282.58	13 3/4	349.25	27 1/2	698.50	18 5/8	473.08	3/4	19.05	12 1/2	317.50	5/8	15.88	13 1/2	342.90	3/8	9.53	-	-
-	1114	11 1/4	285.75	13 7/8	352.43	27 1/2	698.50	19	482.60	3/4	19.05	12 5/8	320.68	5/8	15.88	13 7/8	352.43	3/8	9.53	-	-
-	1138	11 3/8	288.93	14 1/8	358.78	27 1/2	698.50	19	482.60	3/4	19.05	12 3/4	323.85	11/16	17.46	13 7/8	352.43	3/8	9.53	-	-
-	1112	11 1/2	292.10	14 1/4	361.95	27 1/2	698.50	19	482.60	3/4	19.05	12 7/8	327.03	11/16	17.46	13 7/8	352.43	3/8	9.53	-	-
-	1158	11 5/8	295.28	14 3/8	365.13	27 1/2	698.50	19 3/8	492.13	3/4	19.05	13	330.20	11/16	17.46	14 1/8	358.78	3/8	9.53	-	-
-	1134	11 3/4	298.45	14 1/2	368.30	27 1/2	698.50	19 3/8	492.13	3/4	19.05	13 1/8	333.38	11/16	17.46	14 1/8	358.78	3/8	9.53	-	-
-	1178	11 7/8	301.63	14 5/8	371.48	27 1/2	698.50	19 3/8	492.13	3/4	19.05	13 1/4	336.55	11/16	17.46	14 1/8	358.78	3/8	9.53	-	-
-	1200	12	304.80	14 7/8	377.83	30	762.00	19 3/4	501.65	3/4	19.05	13 1/2	342.90	11/16	17.46	14 1/2	368.30	3/8	9.53	-	-
-	1218	12 1/8	307.98	15	381.00	30	762.00	19 3/4	501.65	3/4	19.05	13 5/8	346.08	11/16	17.46	14 1/2	368.30	3/8	9.53	-	-
-	1214	12 1/4	311.15	15 1/8	384.18	30	762.00	19 3/4	501.65	3/4	19.05	13 3/4	349.25	11/16	17.46	14 1/2	368.30	3/8	9.53	-	-
-	1238	12 3/8	314.33	15 1/4	387.35	30	762.00	20 1/8	511.18	7/8	22.23	13 7/8	352.43	11/16	17.46	15 1/8	384.18	3/8	9.53	-	-
863182190	1212	12 1/2	317.50	15 3/8	390.53	30	762.00	20 1/8	511.18	7/8	22.23	14	355.60	11/16	17.46	15 1/8	384.18	3/8	9.53	-	-
-	1258	12 5/8	320.68	15 1/2	393.70	30	762.00	20 1/8	511.18	7/8	22.23	14 1/8	358.78	11/16	17.46	15 1/8	384.18	3/8	9.53	-	-
-	1234	12 3/4	323.85	15 5/8	396.88	30	762.00	20 1/2	520.70	7/8	22.23	14 1/4	361.95	11/16	17.46	15 1/2	393.70	3/8	9.53	-	-
-	1278	12 7/8	327.03	15 3/4	400.05	30	762.00	20 1/2	520.70	7/8	22.23	14 3/8	365.13	11/16	17.46	15 1/2	393.70	3/8	9.53	-	-
-	1300	13	330.20	16	406.40	32 1/2	825.50	20 1/2	520.70	7/8	22.23	14 1/2	368.30	3/4	19.05	15 1/2	393.70	3/8	9.53	-	-
-	1318	13 1/8	333.38	16 1/8	409.58	32 1/2	825.50	21	533.40	7/8	22.23	14 5/8	371.48	3/4	19.05	15 3/4	400.05	3/8	9.53	-	-
-	1314	13 1/4	336.55	16 1/4	412.75	32 1/2	825.50	21	533.40	7/8	22.23	14 3/4	374.65	3/4	19.05	15 3/4	400.05	3/8	9.53	-	-
-	1338	13 3/8	339.73	16 3/8	415.93	32 1/2	825.50	21	533.40	7/8	22.23	14 7/8	377.83	3/4	19.05	15 3/4	400.05	3/8	9.53	-	-
-	1312	13 1/2	342.90	16 1/2	419.10	32 1/2	825.50	21 3/8	542.93	7/8	22.23	15	381.00	3/4	19.05	16 1/4	412.75	3/8	9.53	-	-
-	1358	13 5/8	346.08	16 5/8	422.28	32 1/2	825.50	21 3/8	542.93	7/8	22.23	15 1/8	384.18	3/4	19.05	16 1/4	412.75	3/8	9.53	-	-
-	1334	13 3/4	349.25	16 3/4	425.45	32 1/2	825.50	21 3/8	542.93	7/8	22.23	15 1/4	387.35	3/4	19.05	16 1/4	412.75	3/8	9.53	-	-
-	1378	13 7/8	352.43	16 7/8	428.63	32 1/2	825.50	21 3/4	552.45	7/8	22.23	15 3/8	390.53	3/4	19.05	16 5/8	422.28	3/8	9.53	-	-
-	1400	14	355.60	17	431.80	35	889.00	21 3/4	552.45	7/8	22.23	15 1/2	393.70	3/4	19.05	16 5/8	422.28	3/8	9.53	-	-
-	1418	14 1/8	358.78	17 1/8	434.98	35	889.00	21 3/4	552.45	7/8	22.23	15 5/8	396.88	3/4	19.05	16 5/8	422.28	3/8	9.53	-	-
-	1414	14 1/4	361.95	17 1/4	438.15	35	889.00	22 1/8	561.98	7/8	22.23	15 3/4	400.05	3/4	19.05	17 1/4	438.15	3/8	9.53	-	-
-	1438	14 3/8	365.13	17 3/8	441.33	35	889.00	22 1/8	561.98	7/8	22.23	15 7/8	403.23	3/4	19.05	17 1/4	438.15	3/8	9.53	-	-
-	1412	14 1/2	368.30	17 5/8	447.68	35	889.00	22 1/8	561.98	7/8	22.23	16	406.40	13/16	20.64	17 1/4	438.15	3/8	9.53	-	-
-	1458	14 5/8	371.48	17 3/4	450.85	35	889.00	22 1/2	571.50	7/8	22.23	16 1/8	409.58	13/16	20.64	17 1/2	444.50	3/8	9.53	-	-
-	1434	14 3/4	374.65	17 7/8	454.03	35	889.00	22 1/2	571.50	7/8	22.23	16 1/4	412.75	13/16	20.64	17 1/2	444.50	3/8	9.53	-	-
-	1478	14 7/8	377.83	18	457.20	35	889.00	22 3/4	577.85	7/8	22.23	16 3/8	415.93	13/16	20.64	17 3/4	450.85	3/8	9.53	-	-
-	1500	15	381.00	18 1/8	460.38	35	889.00	22 3/4	577.85	7/8	22.23	16 1/2	419.10	13/16	20.64	17 3/4	450.85	3/8	9.53	-	-

NAVAL BRASS FLANGED

# Flanged Bearing Drilling Diagram

## STRUT OR AFT STERN TUBE BEARINGS

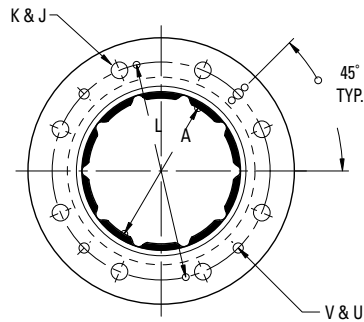

- A** = OD SHAFT OR SLEEVE
- J** = NO. OF HOLES (EQUALLY SPACED)
- K** = DRILL SIZE
- L** = BOLT CIRCLE DIAMETERS
- U** = NO. OF JACKSCREW HOLES (SPACED AS SHOWN)
- V** = JACKSCREW TAP SIZE

A	J	K	L	U	V
6	6	11/16	9	4	1/2
6 1/8	6	11/16	9 1/8	4	1/2
6 1/4	6	11/16	9 1/4	4	1/2
6 3/8	6	11/16	9 3/8	4	1/2
6 1/2	8	11/16	9 5/8	4	1/2
6 5/8	8	11/16	9 3/4	4	1/2
6 3/4	8	11/16	10	4	1/2
6 7/8	8	11/16	10 1/8	4	1/2
7	8	11/16	10 1/4	4	5/8

A	J	K	L	U	V
7 1/8	8	11/16	10 3/8	4	5/8
7 1/4	8	11/16	10 1/2	4	5/8
7 3/8	8	11/16	10 3/4	4	5/8
7 1/2	8	11/16	10 7/8	4	5/8
7 5/8	8	11/16	11	4	5/8
7 3/4	8	11/16	11 1/8	4	5/8
7 7/8	8	11/16	11 1/4	4	5/8
8	8	13/16	11 5/8	4	5/8
8 1/8	8	13/16	11 3/4	4	5/8
8 1/4	8	13/16	11 7/8	4	5/8
8 3/8	8	13/16	12	4	5/8
8 1/2	8	13/16	12 1/8	4	5/8
8 5/8	8	13/16	12 1/4	4	5/8
8 3/4	8	13/16	12 3/8	4	5/8
8 7/8	8	13/16	12 1/2	4	5/8
9	8	13/16	12 5/8	4	3/4
9 1/8	8	13/16	12 3/4	4	3/4
9 1/4	8	13/16	12 7/8	4	3/4
9 3/8	8	13/16	13	4	3/4
9 1/2	8	13/16	13 1/8	4	3/4
9 5/8	8	13/16	13 1/4	4	3/4
9 3/4	8	13/16	13 1/2	4	3/4
9 7/8	8	13/16	13 5/8	4	3/4
10	8	13/16	13 3/4	4	3/4
10 1/8	8	15/16	13 7/8	4	3/4
10 1/4	8	15/16	14	4	3/4
10 3/8	8	15/16	14 1/8	4	3/4
10 1/2	8	13/16	14 1/4	4	3/4
10 5/8	8	13/16	14 3/8	4	3/4
10 3/4	8	13/16	14 1/2	4	3/4
10 7/8	8	15/16	14 7/8	4	3/4
11	8	15/16	15 1/8	4	3/4
11 1/8	8	15/16	15 1/4	4	3/4

A	J	K	L	U	V
11 1/4	8	15/16	15 3/8	4	3/4
11 3/8	10	15/16	15 5/8	4	3/4
11 1/2	10	15/16	15 3/4	4	3/4
11 5/8	10	15/16	15 7/8	4	3/4
11 3/4	10	15/16	16	4	3/4
11 7/8	10	15/16	16 1/8	4	3/4
12	10	15/16	16 3/8	4	3/4
12 1/8	10	15/16	16 1/2	4	3/4
12 1/4	10	15/16	16 5/8	4	3/4
12 3/8	10	15/16	16 3/4	4	3/4
12 1/2	10	15/16	16 7/8	4	3/4
12 5/8	10	15/16	17	4	3/4
12 3/4	10	15/16	17 1/8	4	3/4
12 7/8	10	15/16	17 1/4	4	3/4
13	10	15/16	17 1/2	4	7/8
13 1/8	10	15/16	17 5/8	4	7/8
13 1/4	10	15/16	17 3/4	4	7/8
13 3/8	10	15/16	17 7/8	4	7/8
13 1/2	12	15/16	18	4	7/8
13 5/8	12	15/16	18 1/8	4	7/8
13 3/4	12	15/16	18 1/4	4	7/8
13 7/8	12	15/16	18 3/8	4	7/8
14	12	15/16	18 1/2	4	7/8
14 1/8	12	15/16	18 5/8	4	7/8
14 1/4	12	15/16	18 3/4	4	7/8
14 3/8	12	15/16	18 7/8	4	7/8
14 1/2	12	15/16	19 1/8	4	7/8
14 5/8	12	15/16	19 1/4	4	7/8
14 3/4	12	15/16	19 3/8	4	7/8
14 7/8	12	15/16	19 1/2	4	7/8
15	12	15/16	19 5/8	4	7/8

## FORWARD STERN TUBE BEARINGS

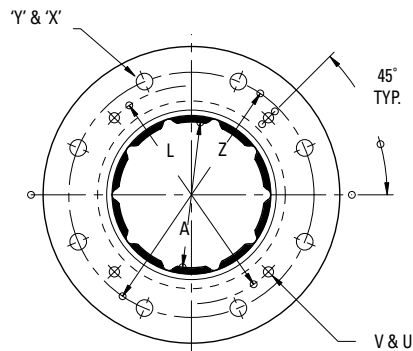

- A** = OD SHAFT OR SLEEVE
- X** = NO. OF HOLES (EQUALLY SPACED)
- Y** = DRILL SIZE
- L & Z** = BOLT CIRCLE DIAMETERS
- U** = NO. OF JACKSCREW HOLES (SPACED AS SHOWN)
- V** = JACKSCREW TAP SIZE

A	X	Y	Z	L	U	V
6	8	11/16	10 1/8	9	4	1/2
6 1/8	8	11/16	10 1/8	9 1/8	4	1/2
6 1/4	8	11/16	10 1/8	9 1/4	4	1/2
6 3/8	8	11/16	10 1/8	9 3/8	4	1/2
6 1/2	8	13/16	11 3/8	9 5/8	4	1/2
6 5/8	8	13/16	11 3/8	9 3/4	4	1/2
6 3/4	8	13/16	12	10	4	1/2
6 7/8	8	13/16	12	10 1/8	4	1/2
7	8	13/16	12	10 1/4	4	5/8

A	X	Y	Z	L	U	V
7 1/8	8	13/16	12 3/8	10 3/8	4	5/8
7 1/4	8	13/16	12 3/8	10 1/2	4	5/8
7 3/8	8	13/16	12 3/8	10 3/4	4	5/8
7 1/2	8	13/16	12 3/4	10 7/8	4	5/8
7 5/8	8	13/16	12 3/4	11	4	5/8
7 3/4	8	13/16	12 3/4	11 1/8	4	5/8
7 7/8	8	13/16	13 1/8	11 1/4	4	5/8
8	8	13/16	13 1/8	11 5/8	4	5/8
8 1/8	8	13/16	13 1/8	11 3/4	4	5/8
8 1/4	8	13/16	13 1/2	11 7/8	4	5/8
8 3/8	8	13/16	13 1/2	12	4	5/8
8 1/2	8	13/16	13 1/2	12 1/8	4	5/8
8 5/8	8	13/16	13 7/8	12 1/4	4	5/8
8 3/4	8	13/16	13 7/8	12 3/8	4	5/8
8 7/8	8	13/16	13 7/8	12 1/2	4	5/8
9	8	13/16	14 1/4	12 5/8	4	3/4
9 1/8	8	13/16	14 1/4	12 3/4	4	3/4
9 1/4	8	13/16	14 1/4	12 7/8	4	3/4
9 3/8	8	13/16	14 5/8	13	4	3/4
9 1/2	8	13/16	14 5/8	13 1/8	4	3/4
9 5/8	8	13/16	14 5/8	13 1/4	4	3/4
9 3/4	8	13/16	15	13 1/2	4	3/4
9 7/8	8	13/16	15	13 5/8	4	3/4
10	8	13/16	15	13 3/4	4	3/4
10 1/8	8	15/16	15 3/4	13 7/8	4	3/4
10 1/4	8	15/16	15 3/4	14	4	3/4
10 3/8	8	15/16	15 3/4	14 1/8	4	3/4
10 1/2	8	15/16	16 1/8	14 1/4	4	3/4
10 5/8	8	15/16	16 1/8	14 3/8	4	3/4
10 3/4	8	15/16	16 1/8	14 1/2	4	3/4
10 7/8	8	15/16	16 1/2	14 7/8	4	3/4
11	8	15/16	16 1/2	15 1/8	4	3/4
11 1/8	8	15/16	16 1/2	15 1/4	4	3/4

A	X	Y	Z	L	U	V
11 1/4	8	15/16	16 7/8	15 3/8	4	3/4
11 3/8	8	15/16	16 7/8	15 5/8	4	3/4
11 1/2	8	15/16	16 7/8	15 3/4	4	3/4
11 5/8	12	15/16	17 1/4	15 7/8	4	3/4
11 3/4	12	15/16	17 1/4	16	4	3/4
11 7/8	12	15/16	17 1/4	16 1/8	4	3/4
12	12	15/16	17 5/8	16 3/8	4	3/4
12 1/8	12	15/16	17 5/8	16 1/2	4	3/4
12 1/4	12	15/16	17 5/8	16 5/8	4	3/4
12 3/8	12	15/16	18	16 3/4	4	3/4
12 1/2	12	15/16	18	16 7/8	4	3/4
12 5/8	12	15/16	18	17	4	3/4
12 3/4	12	15/16	18 3/8	17 1/8	4	3/4
12 7/8	12	15/16	18 3/8	17 1/4	4	3/4
13	12	15/16	18 3/8	17 1/2	4	7/8
13 1/8	12	15/16	18 7/8	17 5/8	4	7/8
13 1/4	12	15/16	18 7/8	17 3/4	4	7/8
13 3/8	12	15/16	18 7/8	17 7/8	4	7/8
13 1/2	12	15/16	19 1/4	18	4	7/8
13 5/8	12	15/16	19 1/4	18 1/8	4	7/8
13 3/4	12	15/16	19 1/4	18 1/4	4	7/8
13 7/8	12	15/16	19 5/8	18 3/8	4	7/8
14	12	15/16	19 5/8	18 1/2	4	7/8
14 1/8	12	15/16	19 5/8	18 5/8	4	7/8
14 1/4	12	15/16	20	18 3/4	4	7/8
14 3/8	12	15/16	20	18 7/8	4	7/8
14 1/2	12	15/16	20	19 1/8	4	7/8
14 5/8	12	15/16	20 3/8	19 1/4	4	7/8
14 3/4	12	15/16	20 3/8	19 3/8	4	7/8
14 7/8	12	15/16	20 5/8	19 1/2	4	7/8
15	12	15/16	20 5/8	19 5/8	4	7/8

**Clearances and tolerances.**

Johnson® Cutless® bearings are furnished with the correct clearance to fit the specified shaft size. In every case, the shaft should have an easy running fit through the bearing, it must never be forced through the bearing.

For applications where the bearing lubrication exceeds 95°F, greater bearing clearances are required. Complete operating requirements including maximum ambient water temperature and loading requirements should be provided to Duramax® engineering for review.

It is difficult to make accurate I.D. measurements on a Johnson® Cutless® that is less than six inches in diameter with a two-point micrometers since the soft rubber lining will deflect. In addition, variations in ambient temperature will produce dimensional changes in Johnson® Cutless® bearings because of the coefficient of thermal expansion of rubber is substantially greater than for metals. Therefore, the best practice is to always check the inside diameter measurements of smaller bearings with plug gages.



The following are the standards as established by the U.S. Navy, according to BuShips plan number 810-1385664, dated 14 January 1963 "Bearing Stern Tube and Strut".

Shaft or Sleeve Size			Shaft Clearance*		
3/4"	thru	1 3/8"	+0.003	to	+0.008
1 7/16"	thru	1 7/8"	+0.004	to	+0.010
2"	thru	2 3/8"	+0.006	to	+0.012
2 1/2"	thru	3"	+0.007	to	+0.014
3 1/8"	thru	3 3/4"	+0.008	to	+0.015
3 7/8"	thru	4 1/4"	+0.010	to	+0.017
4 3/8"	thru	4 7/8"	+0.012	to	+0.019
5"	thru	5 3/8"	+0.015	to	+0.023
5 1/2"	thru	5 7/8"	+0.017	to	+0.025
6"	thru	6 3/8"	+0.020	to	+0.029
6 1/2"	thru	6 7/8"	+0.022	to	+0.032
7"	thru	7 3/8"	+0.024	to	+0.034
7 1/2"	thru	7 7/8"	+0.025	to	+0.035
8"	thru	8 3/8"	+0.027	to	+0.037
8 1/2"	thru	8 7/8"	+0.028	to	+0.040
9"	thru	9 7/8"	+0.030	to	+0.042
10"	thru	10 7/8"	+0.032	to	+0.044
11"	thru	11 3/8"	+0.034	to	+0.048
11 1/2"	thru	12 3/4"	+0.035	to	+0.050
12 7/8"	thru	13 3/8"	+0.037	to	+0.052
13 1/2"	thru	14 1/2"	+0.040	to	+0.055
14 5/8"	thru	15"	+0.042	to	+0.058

O.D. Tolerance					
1 1/4"	thru	2"	+0.001	to	-0.001
2"	thru	6"	+0.002	to	-0.001
6"	thru	7 1/2"	+0.002	to	-0.002
7 3/4"	thru	12"	+0.005	to	-0.005
12"	thru	16"	+0.006	to	-0.006
16"	thru	18"	+0.008	to	-0.008

**ALL DIMENSIONS IN INCHES**

\* Due to recent changes to stainless steel shafting tolerances, Duramax Marine® has adjusted bearing overshaft clearances to compensate for positive diametrical tolerances. Please contact Duramax Marine® for overshaft bearing clearance.

# Rudder Bushings

## DX490



**DX490 Rudder Bushings** are molded from a 70 Scale D, Durometer, Nitrile Rubber Compound (approximately the same hardness as a bowling ball). They are formulated to withstand the rugged "impact" service encountered in ship's rudder steering systems. DX490 has high rigidity for maximum dimensional stability while still retaining a degree of resiliency required to dampen peak shock loads.

**DX490 Rudder Bushings** are supplied as unfinished cylinders molded with longitudinal lubrication grooves. The bushings can be easily machined in a local machine shop for proper fit. Grease, oil and water serve equally well as lubricants. The DX490 Rudder Bushing is resistant to deterioration by hydrocarbons, acids, salt water corrosion and electrolysis.

**CAUTION:**

DX490 Rudder Bushings are supplied as unfinished with molded I.D. and O.D. dimensions which allow ample material for finish machining. However, when finish boring I.D. dimensions do not remove more than 70% of the lubricant groove depth.

**IMPORTANT:** In addition to interference press fit, DX490 Rudder Bushings must be mechanically secured with set screws or other locking devices to prevent movement during operation and the expected operating temperature range.

FIGURE 13

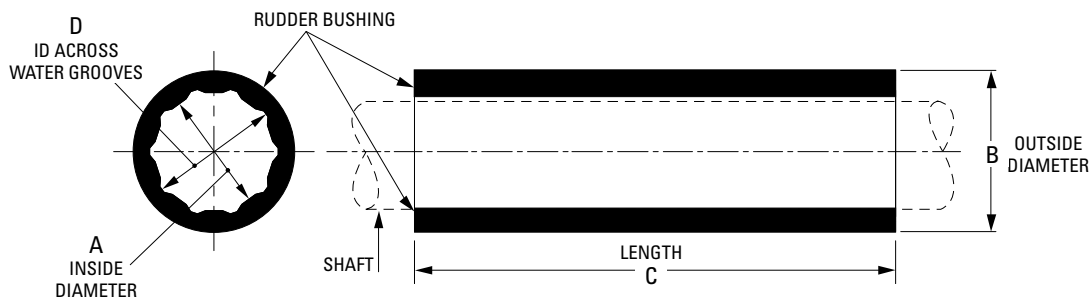

Part Number	Code	A Inside Diameter		B Outside Diameter		C Length		D ID Across Water Grooves		Gross Wt.	
		inches	mm	inches	mm	inches	mm	inches	mm	lb.	kg.
812100038	DX150	1.45	36.83	2.35	59.69	11	279.40	1.62	41.15	1.0	0.5
812100044	DX175	1.70	43.18	2.59	65.79	13	330.20	1.97	50.04	1.5	0.7
812100051	DX200	1.95	49.53	3.07	77.98	15	381.00	2.20	55.88	2.5	1.1
812100057	DX225	2.18	55.37	3.32	84.33	7 1/2	190.50	2.57	65.28	2.3	1.0
812100064	DX250	2.44	61.98	3.68	93.47	9	228.60	2.75	69.85	2.7	1.2
812100070	DX275	2.70	68.58	3.92	99.57	10	254.00	2.97	75.44	3.0	1.4
812100076	DX300	2.95	74.93	4.20	106.68	11	279.40	3.39	86.11	4.0	1.8
812100083	DX325	3.19	81.03	4.42	112.27	12	304.80	3.60	91.44	4.0	1.8
812100089	DX350	3.34	84.84	5.19	131.83	13	330.20	3.76	95.50	7.5	3.4
812100095	DX375	3.66	92.96	5.18	131.57	14	355.60	4.05	102.87	6.5	2.9
812100102	DX400	3.93	99.82	5.45	138.43	15	381.00	4.28	108.71	7.5	3.4
812100108	DX425	4.16	105.66	5.68	144.27	16	406.40	4.55	115.57	9.0	4.1
812100114	DX450	4.42	112.27	6.02	152.91	17	431.80	4.68	118.87	11.0	5.0
812100121	DX475	4.65	118.11	6.01	152.65	18	457.20	5.05	128.27	10.0	4.5
812100127	DX500	4.93	125.22	6.68	169.67	19	482.60	5.31	134.87	15.0	6.8
812100135	DX525	5.15	130.81	6.90	175.26	20 1/2	520.70	5.64	143.26	17.0	7.7
812100140	DX550	5.39	136.91	7.61	193.29	21	533.40	5.91	150.11	21.0	9.5
812100146	DX575	5.65	143.51	7.65	194.31	22	558.80	6.00	152.40	22.0	10.0
812100152	DX600	5.87	149.10	8.65	219.71	22	558.80	6.40	162.56	24.0	10.9
812100165	DX650	6.36	161.54	8.67	220.22	22	558.80	6.84	173.74	27.8	12.6
812100171	DX675	6.65	168.91	9.00	228.60	23	584.20	7.16	181.86	31.0	14.1
812100178	DX700	6.88	174.75	9.08	230.63	24 1/2	622.30	7.35	186.69	31.0	14.1
812100184	DX725	7.10	180.34	10.47	265.94	27 1/2	698.50	7.60	193.04	38.0	17.2
812100191	DX750	7.33	186.18	10.47	265.94	27 1/2	698.50	8.07	204.98	35.0	15.9
812100197	DX775	7.70	195.58	10.47	265.94	27 1/2	698.50	8.30	210.82	45.0	20.4
812100203	DX800	7.82	198.63	10.56	268.22	29 1/2	749.30	8.50	215.90	50.0	22.7
812100216	DX850	8.37	212.60	12.20	309.88	35	889.00	9.09	230.89	65.0	29.5
812100222	DX875	8.64	219.46	11.32	287.53	32 1/2	825.50	9.11	231.39	58.0	26.3
812100229	DX900	8.89	225.81	11.32	287.53	32 1/2	825.50	9.49	241.05	73.0	33.1
812100235	DX925	9.11	231.39	12.22	310.39	35	889.00	9.72	246.89	85.0	38.6

# DX490 NON-METALLIC BUSHINGS

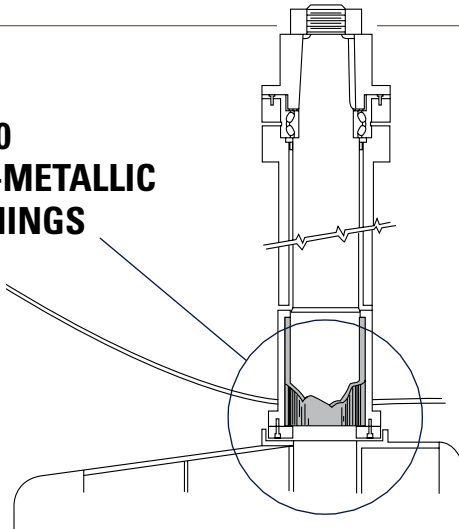

## PHYSICAL PROPERTIES:

Deformation	Load PSI	Deflection	Temperature	
	225	.004"	72° F	
	300	.0045"	72° F	
Compressive Strength	15,000	Elastic Limit	72° F	
Tensile	3000 PSI			
Expansion and Contraction	Configuration	Contraction	Temp.	Recovery
	Std. Tubular	.002" -.0025" per inch of OD	-20° F	100%
Absorption	Aging	Liquid	Temp.	Vol. Change %
	70 hrs.	ASTM #3 Oil	212° F	+ 4.9%
	70 hrs.	ASTM #3 Oil	100° F	+ less than 1%
	70 hrs.	ASTM #3 Oil	72° F	Negligible
	70 hrs.	H <sub>2</sub> O	212° F	+ 2.6%
	70 hrs.	H <sub>2</sub> O	100° F	Negligible
Range of working temperature -20° to 180° continuous service.				

## CALCULATING THE FINISHED (MACHINED) SIZE OF DX490

Nominal Bushing I.D. and O.D. dimensions must be adjusted to allow for proper shaft to bearing running clearance, thermal expansion and contraction and interference press fit. Before machining, calculate the finished machined bearing I.D. and O.D. dimensions as follows:

### EXAMPLE:

Nominal Shaft Diameter: 8 inches  
Nominal Bearing Housing Diameter: 12 inches

### To determine the finished machined bearing I.D. dimension

refer to the machining tables and add the running clearance (Table X), thermal factor (Table Y) and press fit allowance (Table Z), to the nominal shaft diameter.

Finished Machined Bearing I.D. Dimension equals:

+ Nominal Bearing Shaft Diameter 8.000  
+ Running Clearance (Table X) 0.018  
+ Thermal Factor (Table Y) 0.016  
+ Press Fit Allowance (Table Z) 0.008  
8.042 inches I.D.

### To determine the finished machined bearing O.D. dimension

Refer to the machining tables and add the thermal factor (Table Y) and the press fit allowance (Table Z), to the nominal bearing housing diameter.

Finished Machined Bearing O.D. Dimension equals:

+ Nominal Bearing Housing Diameter 12.000  
+ Thermal Factor (Table Y) 0.016  
+ Press Fit Allowance (Table Z) 0.008  
12.024 inches O.D.

**TABLE X — RUNNING CLEARANCE**

Nominal ID inches	2	3	4	5	6	7	8	9	10	11	12	13	14
Allowance inches	0.012	0.013	0.014	0.015	0.016	0.017	0.018	0.019	0.020	0.021	0.022	0.023	0.024
Nominal ID mm	50.80	76.20	101.60	127.00	152.40	177.80	203.20	228.60	254.00	279.40	304.80	330.20	355.60
Allowance mm	0.30	0.33	0.36	0.38	0.41	0.43	0.46	0.48	0.51	0.53	0.56	0.58	0.61

**TABLE Y — THERMAL FACTOR**

Nominal ID inches	2	3	4	5	6	7	8	9	10	11	12	13	14
Allowance inches	0.004	0.006	0.008	0.010	0.012	0.014	0.016	0.018	0.020	0.022	0.024	0.026	0.028
Nominal ID mm	50.80	76.20	101.60	127.00	152.00	177.80	203.20	228.60	254.00	279.40	304.80	330.20	355.60
Allowance mm	0.10	0.15	0.20	0.25	0.30	0.35	0.41	0.46	0.51	0.56	0.61	0.66	0.71

**TABLE Z — PRESS FIT ALLOWANCE**

Nominal ID inches	2	3	4	5	6	7	8	9	10	11	12	13	14
Allowance inches	0.005	0.005	0.005	0.005	0.005	0.008	0.008	0.008	0.008	0.010	0.010	0.010	0.010
Nominal ID mm	50.80	76.20	101.60	127.00	152.00	177.80	203.20	228.60	254.000	279.40	304.80	330.20	355.60
Allowance mm	0.13	0.13	0.13	0.13	0.13	0.20	0.20	0.20	0.20	0.25	0.25	0.25	0.25

# Johnson® Cutless® Water-Lubricated Bearing Systems

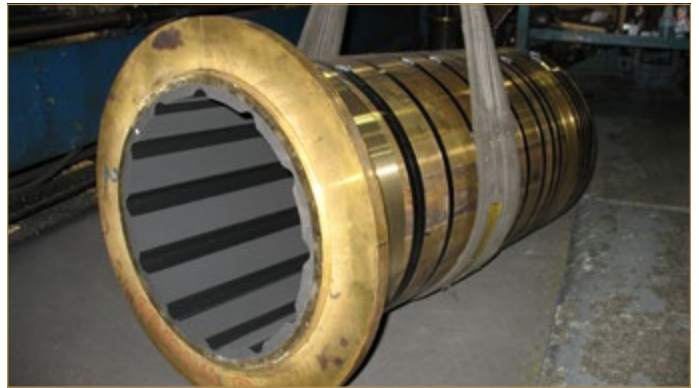



INNOVATION.  
EXPERIENCE.  
RESULTS.

Duramax Marine® is committed to providing excellence in every product we manufacture. Our Johnson Cutless® marine and industrial bearings, heat exchangers, impact protection systems and sealing systems are known worldwide for their engineered quality and dependable performance. Please contact the factory for information on any of the following Duramax Marine® products:



## JOHNSON CUTLESS® WATER-LUBRICATED BEARING SYSTEMS

Johnson Cutless® Sleeve and Flanged Bearings  
DX 490 Rudder Bushings



## DURAMAX® ADVANCED WATER-LUBRICATED BEARING SYSTEMS

Johnson® Demountable Stave Bearings  
ROMOR® I Stave Bearings and Segmental Housings  
ROMOR® C- Partial Arc Bearings  
DMX® Polymer Alloy Bearings  
DuraBlue® Bearings, Rudder & Pintle Bushings, Thrust Washers, and Wear Pads  
Industrial Pump Bearing Systems



## DURAMAX® HEAT EXCHANGE SYSTEMS

DuraCooler® Keel Coolers  
Duramax® Demountable Keel Coolers  
Duramax® BoxCoolers  
Duramax® Plate Heat Exchangers

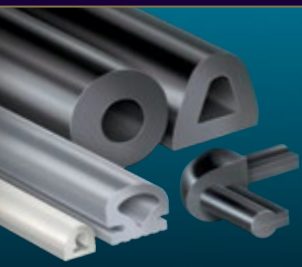

## DURAMAX® IMPACT PROTECTION SYSTEMS

Johnson® Commercial Dock Bumpers, Fenders & Tow Knees  
Weatherstrip Door Gaskets, Window Channel and Hatch Cover Gaskets  
LINERITE® Composite Batterboard Systems



## DURAMAX® SHAFT SEALING SYSTEMS

DryMax® Shaft Seal & Rudder Seal  
Duramax® Mechanical Shaft Seal  
Johnson® Heavy-Duty Air Seal Stuffing Boxes  
Duramax® Ultra-X® High Performance Compression Packing  
Johnson® Strong Boy Stern Castings and Stuffing Boxes

©2021 Duramax Marine®  
17990 Great Lakes Parkway  
Hiram, Ohio 44234 U.S.A.

PHONE 440.834.5400  
FAX 440.834.4950

info@DuramaxMarine.com  
www.DuramaxMarine.com

Duramax Marine® is an ISO 9001:2015 Certified Company

# DURAMAX MARINE®